

Core I3

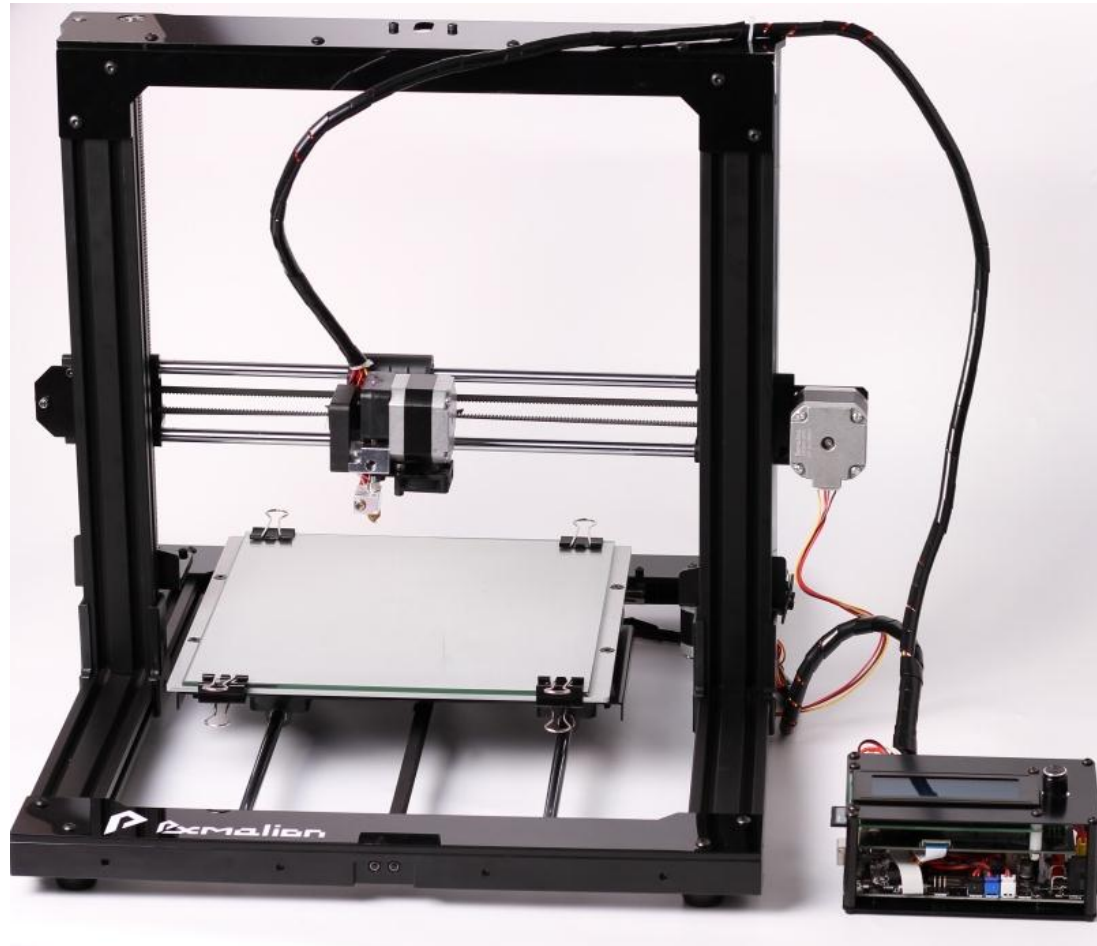





Assembly Instructions



I Components

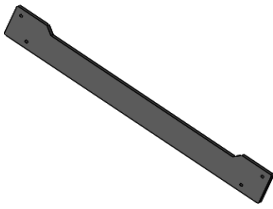
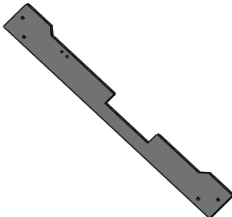
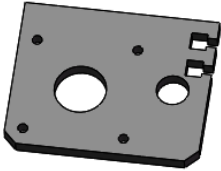
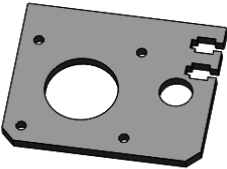
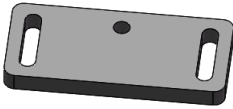
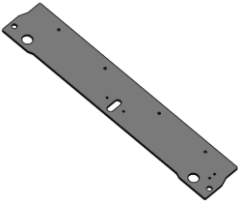



 <p>2PCS(340mm)</p>	 <p>2PCS(400mm)</p>		
1	2	3	4
			
5	6	7	8
	 <p>3PCS</p>	 <p>4PCS</p>	
9	10	11	12



 <p>2PCS(Ø8*343mm)</p>	 <p>2PCS(Ø8*420mm)</p>	 <p>2PCS(Ø10*321mm)</p>	 <p>1PC(T8*299mm)</p>
<p>1</p>	<p>2</p>	<p>3</p>	<p>4</p>
 <p>1PC(T8*321mm)</p>	 <p>3PCS</p>	 <p>6PCS</p>	 <p>4PCS</p>
<p>5</p>	<p>6</p>	<p>7</p>	<p>8</p>
		 <p>1PC (30*30mm. W×H)</p>	 <p>1PC (40*40mm. W×H)</p>
<p>9</p>	<p>10</p>	<p>11</p>	<p>12</p>

 <p>3PCS</p>			
13	14	15	16
			
17	18	19	20
			
21	22	23	24
			
25	26	27	28



1

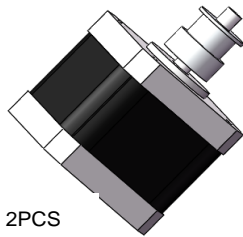

2PCS

2

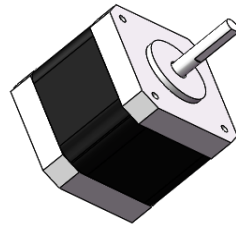

1PC

3



2PCS

4



5



6



7

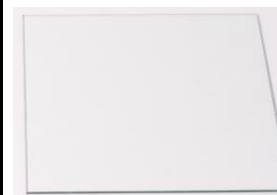

8



9

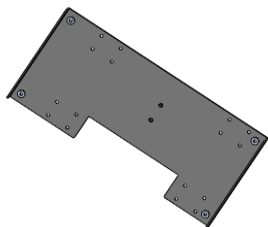

10

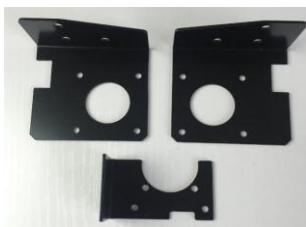

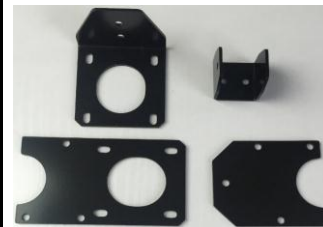

11



12

			 <p>4PCS</p>
13	14	15	16
			
17	18	19	20

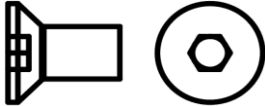
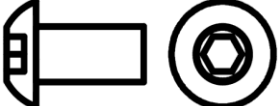
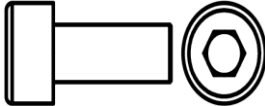
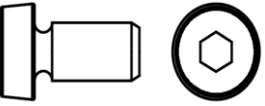
Screw Packing List

Bag #1				Countersink head hex socket screw
Item	Descriptions	Specs	Quantity	
1	Countersink head hex socket screw	Carbon steel, M4x8	8	
2	Botton head hex socket screw	Carbon steel, M4x8	20	
3	T-nut	EU style, M4x10x6	32	
4	Cup head hex socket screw	Carbon steel, M4x14	4	
5	Cup head hex socket screw	Carbon steel, M3x8	7	
Bag #2				Botton head hex socket screw
Item	Descriptions	Specs	Quantity	
1	Lock nut	304 stainless steel, M4	10	
2	Botton head hex socket screw	Carbon steel, M4x25	10	
3	Cup head hex socket screw	Carbon steel, M3x16	2	
4	Cup head hex socket screw	Carbon steel, M3x10	10	
Bag #3				Cup head hex socket screw
Item	Descriptions	Specs	Quantity	
1	Countersink head hex socket screw	Carbon steel, M4x35	4	
2	Spring	/	4	
3	Cup head hex socket screw	Carbon steel, M3x14	7	
Bag #4				Cup head hex socket self-tapping screw
Item	Descriptions	Specs	Quantity	
1	Lock nut	304 stainless steel, M3	35	
2	Cup head hex socket screw	Carbon steel, M3x25	2	
3	Cup head hex socket screw	Carbon steel, M3x18	7	
4	Cup head hex socket screw	Carbon steel, M3x12	10	
5	Cup head hex socket screw	Carbon steel, M3x6	14	
Bag #5				T-nut
Item	Descriptions	Specs	Quantity	
1	Filament tube	4*2	1	
2	Nylon spacer	2	1	
3	Nylon spacer	4	5	
4	Nylon spacer	6	2	
5	Cup head hex socket self-tapping screw	Carbon steel, M3x12	2	

Tools:



Screws and nuts:

Please refer to below pictures for definitions of screws and nuts to be used.

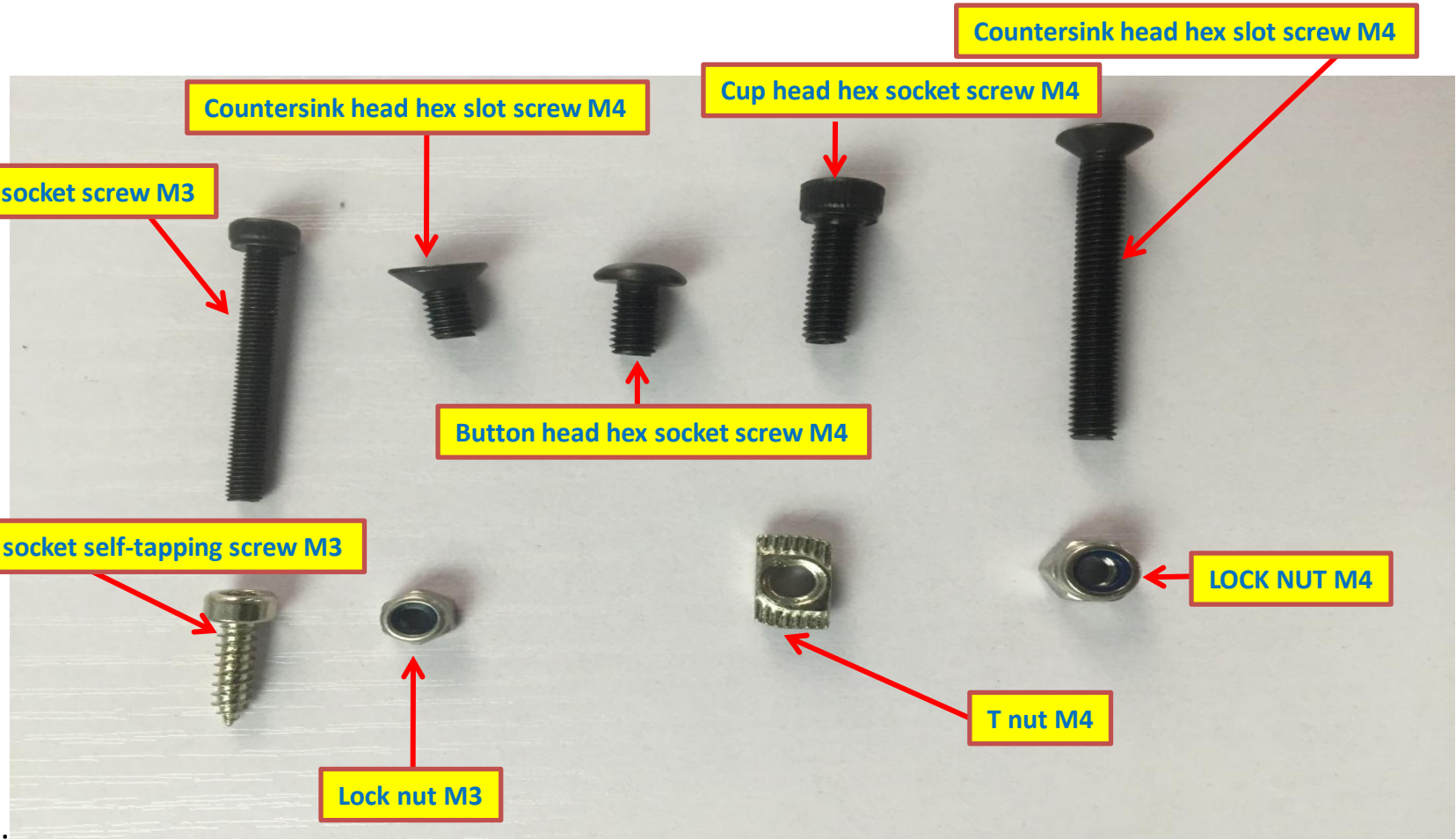

Notes:

1. T nut must be flat in aluminum profile slot, when a screw is turned into it, it wouldn't follow as fixed by walls of slot, thus screw can be tightened. If it's not in correct position, screw won't be able to be tightened into it.
2. Definitions of screw spec M3X8, M3X10, M4X8, M4X10,: M3 or M4 indicates the tooth type and diameter, x8 or x10 means its length.

II List of Tools

Wrench x 1 (5.5-7mm), Allen Keys x 4 (Size: 1.5, 2, 2.5, 3mm), Scissor x1

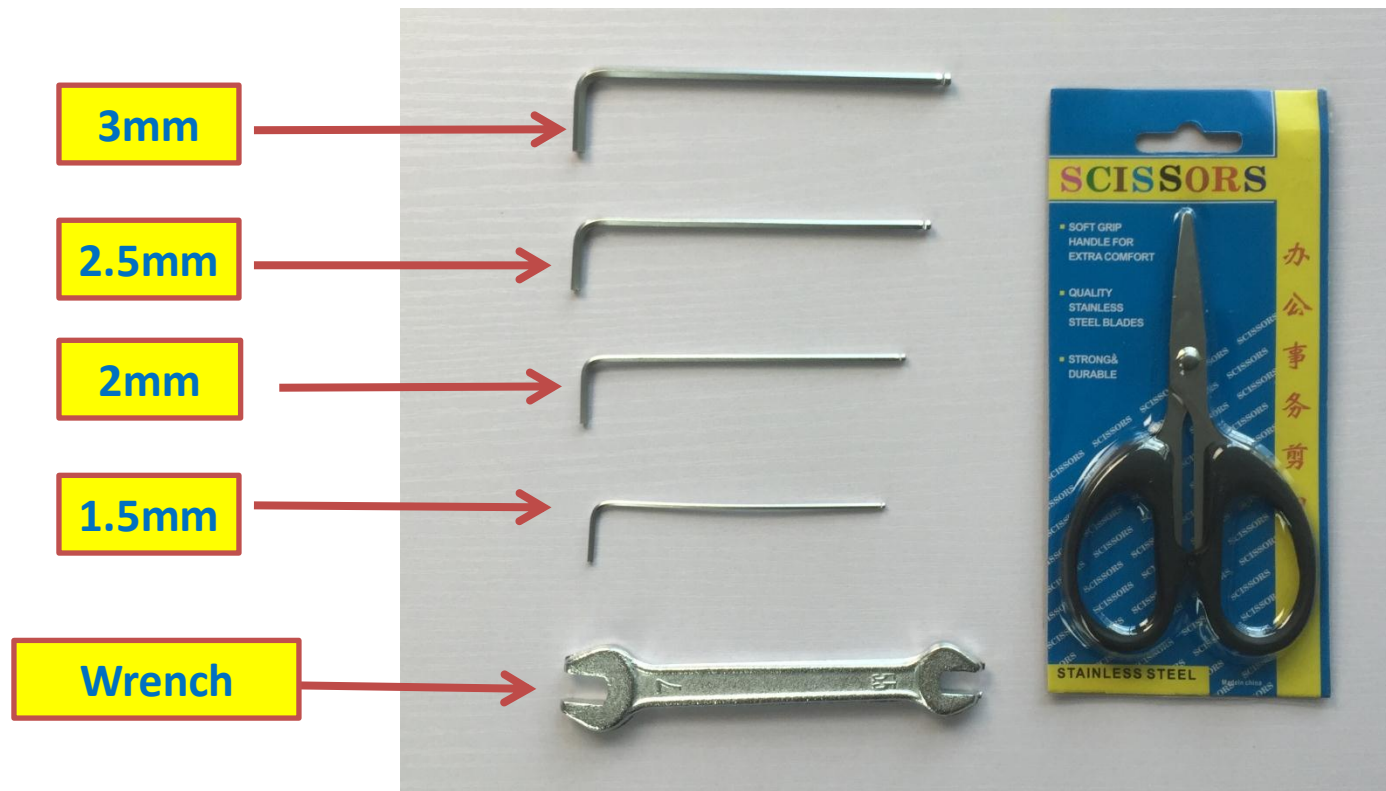

III Sequence of Assembly

1. Prepare to assemble Y motion system
 - 1.1 Assembly the frame
 - 1.2 Install the stroke switch for Y motion
 - 1.3 Pre-install the PMMA covers

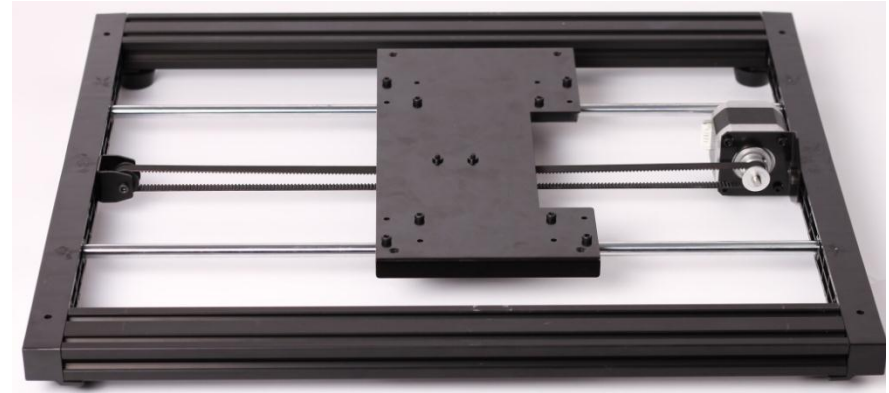

2. Assembly Y motion system
 - 2.1 Build up the idle pulley assembly
 - 2.2 Mount pulley assembly to the frame
 - 2.3 Mount Y motion motor
 - 2.4 Install the foot pads and a piece of profile
 - 2.5 Put the timing belt on
 - 2.6 Fix the PMMA covers

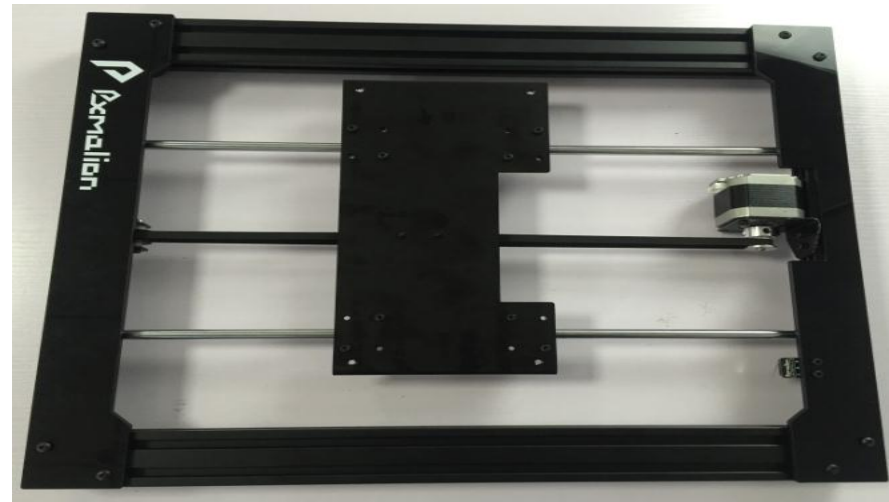

3. Add X motion system

3.1 Assemble the sliding mechanisms

3.2 Install the idle pulley

3.3 Install the stroke switch

3.4 Install 2 driving screws

3.5 Install X motion motor

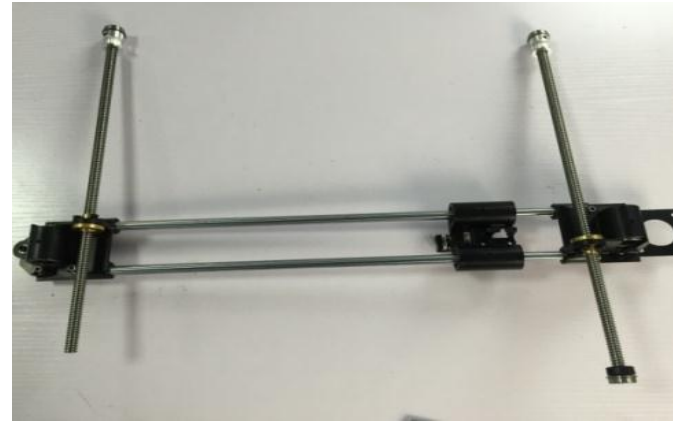
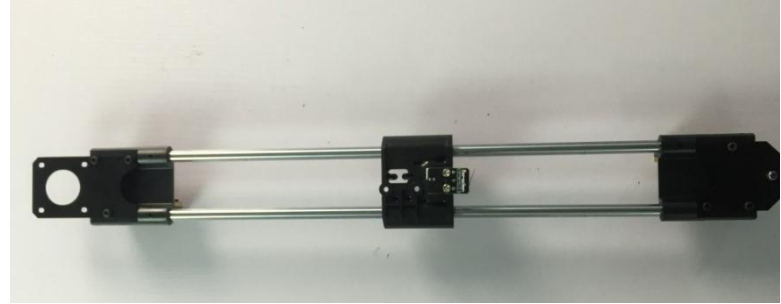

4. Prepare to assemble Z motion system

4.1 Assembly Z motion motor assembly

4.2 Install the right angle pieces

4.3 Install the belt adjustment block

4.4 Install the frame (profiles) for Z motion

4.5 Install Z motion motor assembly

4.6 Install the connection bar

4.7 Install the decoration plate

4.8 Fix the 2 driving screws

4.9 Install the timing belt

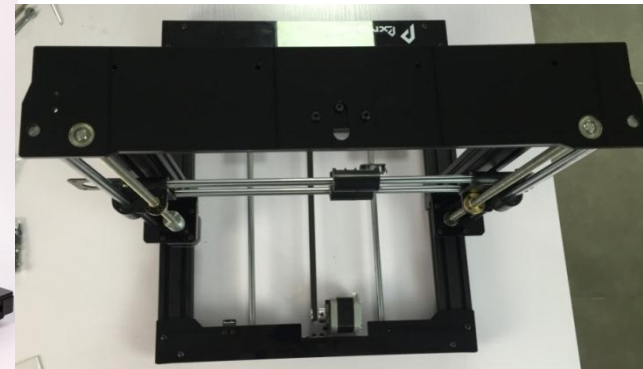

5. Assemble hot end assembly
 - 5.1 Install the smaller cooling fan
 - 5.2 Install extrusion motor
 - 5.3 Assemble nozzle and connected components together
 - 5.4 Install the bigger fan
 - 5.5 Install nozzle assembly
 - 5.6 Install X motion belt

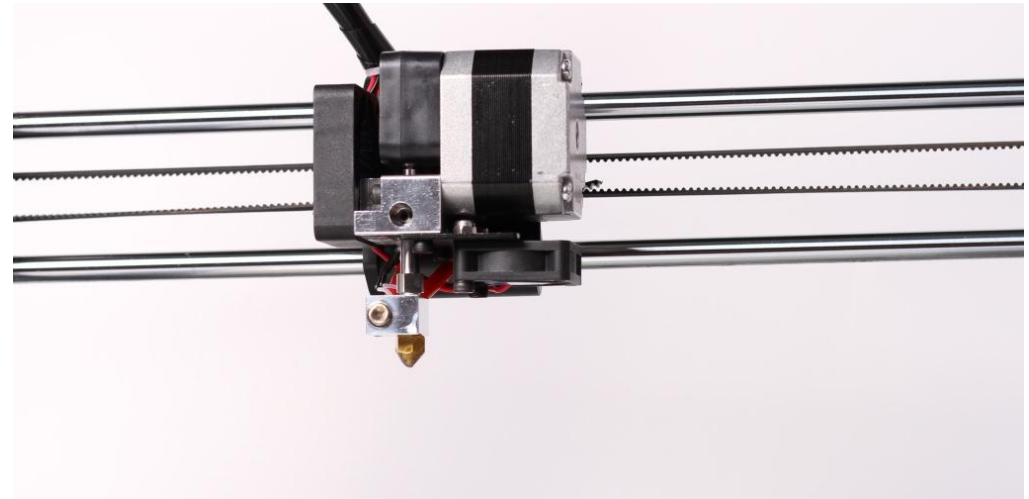

6. Install the platform
 - 6.1 Install the heating plate
 - 6.2 Put on the glass top



- 7. Wire connection instructions
 - 7.1 Connect wires to 3d printer
 - 7.2 Connect wires to control box

8. Z motion system self-adjustment

9. Filament sensor installation

10. First print after set up

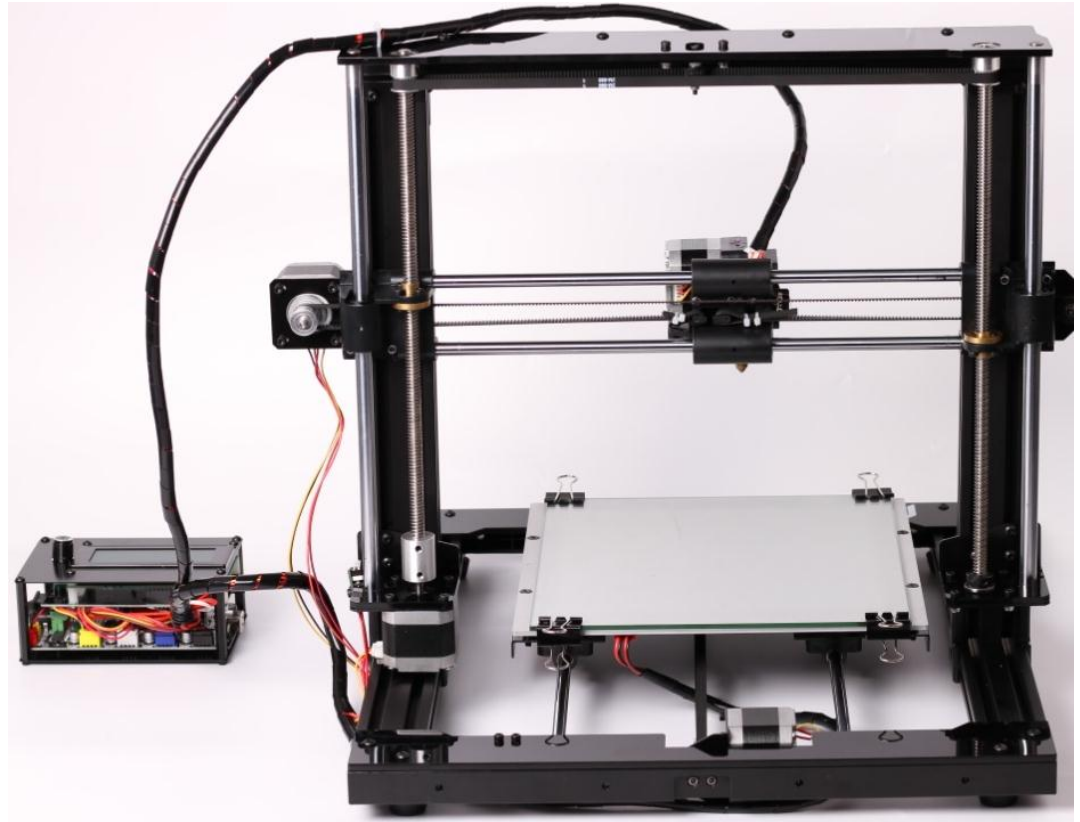

IV Process Details of Assembly

Material list #1:

Sequence	#	Description	Q'TY	Remark
Y motion system assembly	1	Aluminum profile	2	The longer ones
	2	Connection bar	2	Plastic
	3	Guiding pin	2	The longest
	4	Slider	4	Plastic
	5	Foot pad	4	
	6	Idle pulley seat for Y	1	Sheet steel
	7	Motor seat for Y	1	Sheet steel
	8	Platform	1	Sheet steel
	9	Idle pulley	2	Plastic
	10	Pulley	1	Pre-assembled to motor
	11	Stepper motor	1	
	12	Timing belt	1	Open ended one with shorter length
	13	PMMA pc - A	1	PMMA
	14	PMMA pc - B	1	PMMA
	15	Stroke switch	1	
	16	Nylon spacer	2	Height: 4mm
	17	Belt clip for Y	1	Plastic



Attention:

- ① Use the longer aluminum profiles for this step.
- ② Use the open-ended timing belt with shorter length for this step.

1.1 Platform assembly

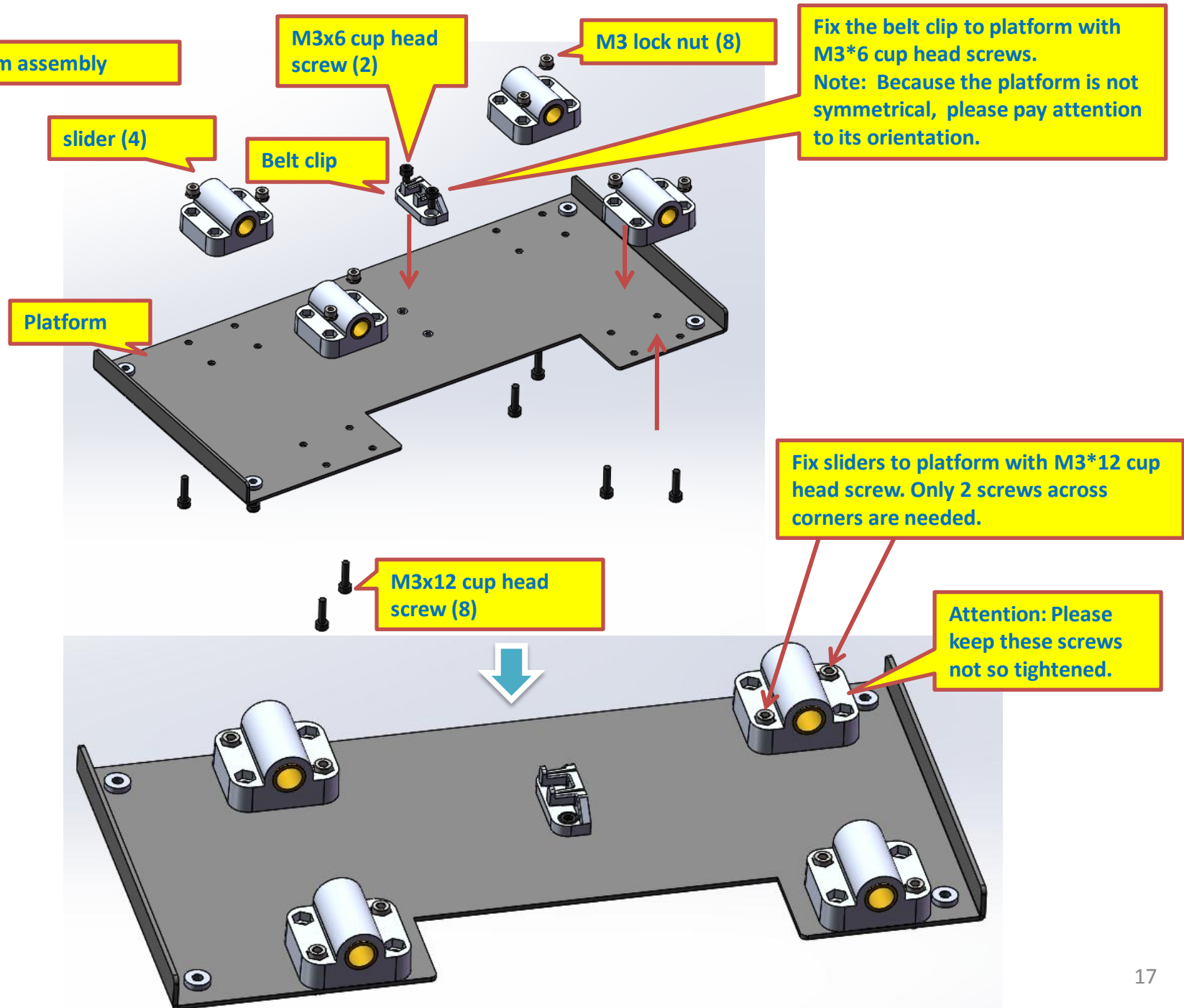

1.2 Remove the protective film from PMMA plates



These 2 PMMA plates will be used for the next step.

Install the stroke switch with screws / nuts, pay attention to its orientation.



4mm nylon spacer

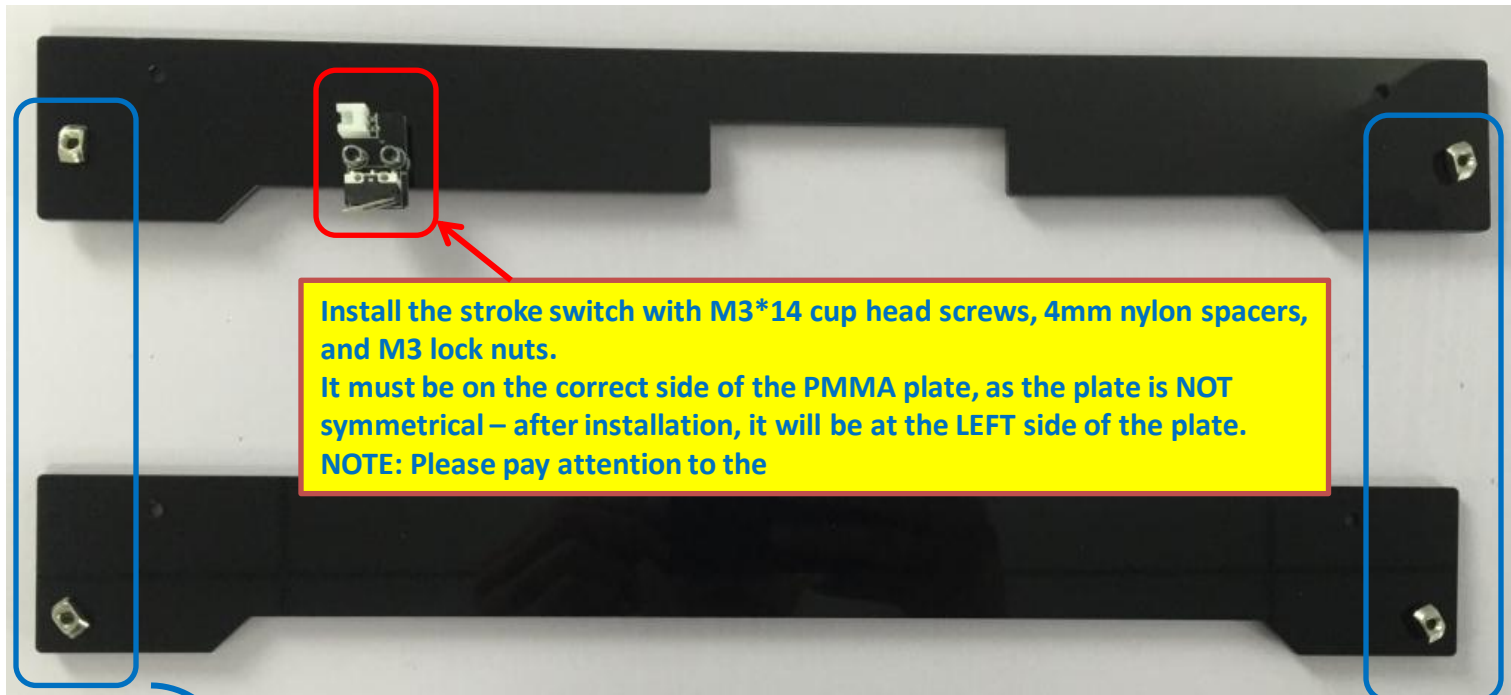

Install the stroke switch with M3*14 cup head screws, 4mm nylon spacers, and M3 lock nuts.
It must be on the correct side of the PMMA plate, as the plate is NOT symmetrical – after installation, it will be at the LEFT side of the plate.
NOTE: Please pay attention to the

Add M4*8 button head screws and T nuts to PMMA plate, just hang them there on the plate and do not tighten them.

1.3 Pre-install the PMMA covers

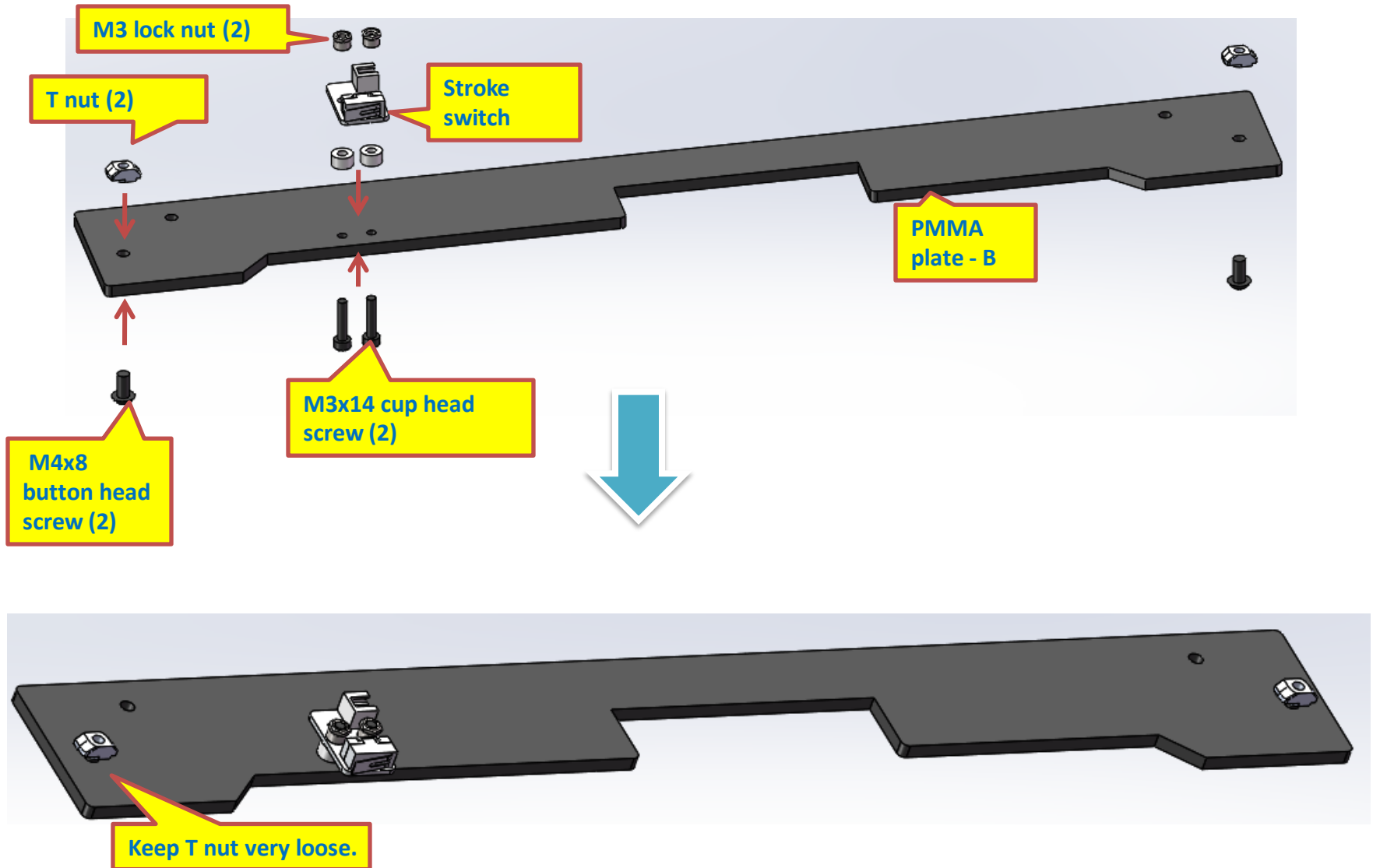

2. Assembly Y motion system

2.1 Build up the idle pulley assembly (3 sets needed)

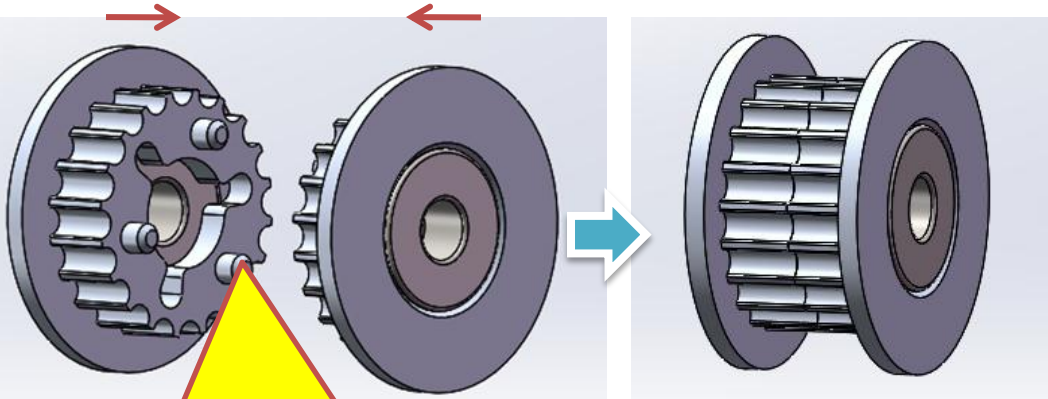

The 2 sides of idle pulley is snapping fitted with 3 pillars into slots. Pay attention to the orientation to ensure they match EXACTLY.

The teeth of the 2 sides must match EXACTLY.



'V'



'X'

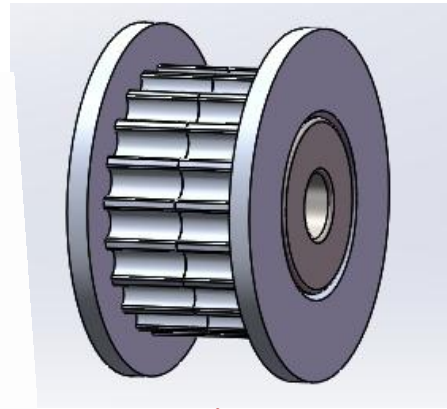
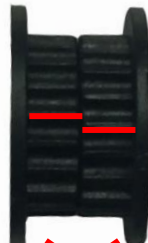

'V'

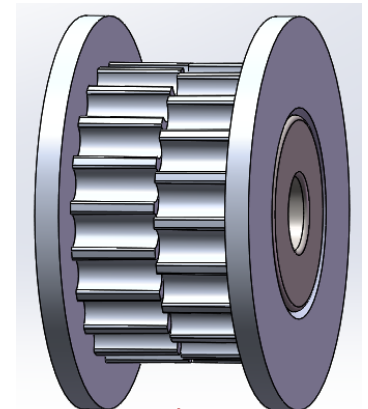

'X'

2.2 Mount pulley assembly to the frame

- ① Fix the idle pulley seat to the connection bar with M3*18 cup head screws.
- ② Then add the idle pulley by using M3*25 cup head screw, 4mm nylon spacers, and M3 lock nuts.

M3 lock nut (3)

Idle pulley seat for Y (black sheet steel component)

M3 lock nut

M3x18 cup head screw (2)

M3x25 cup head screw

Idle pulley

4mm nylon spacer (2)

Attention :
DON'T over tighten the screw. When the pulley is touched by hand, it should be able to move smoothly.

2.3 Install motor for Y motion

- ① Secure motor seat for Y to connection bar with M3*8 cup head screws and M3 lock nuts.
- ② Add motor to motor seat with M3*6 cup head screws. DON'T tighten the screws now since motor position will be adjusted later.
- ③ Secure the pulley to the shaft of motor. Pay attention to the orientation of the pulley and keep distance between it and the motor housing.

U shaped holes:
DON'T tighten
the screws in
order to adjust
motor position
later.

M3 LOCK
NUT (2)

Attention: Do not
mistake the
orientation of the
socket.

Stepper
motor

Pay attention to the orientation
of the pulley.

Motor seat for Y
(BLACK sheet steel part)

M3x6 cup
head
screw (4)

Connection bar

M3x18 cup head screw
(2)

Keep 3-4mm gap here.

2.4 Assemble Y motion system frame and foot pads

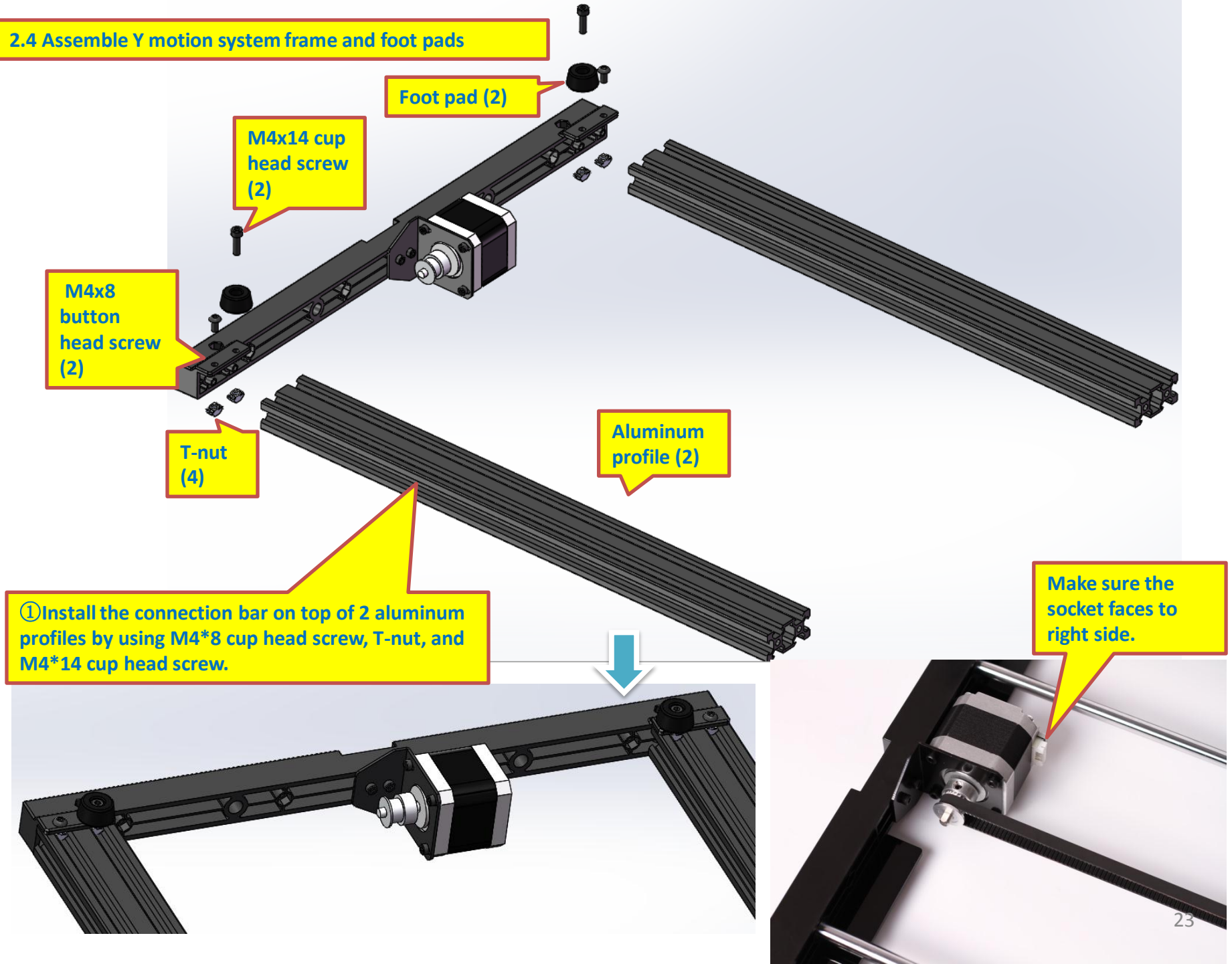

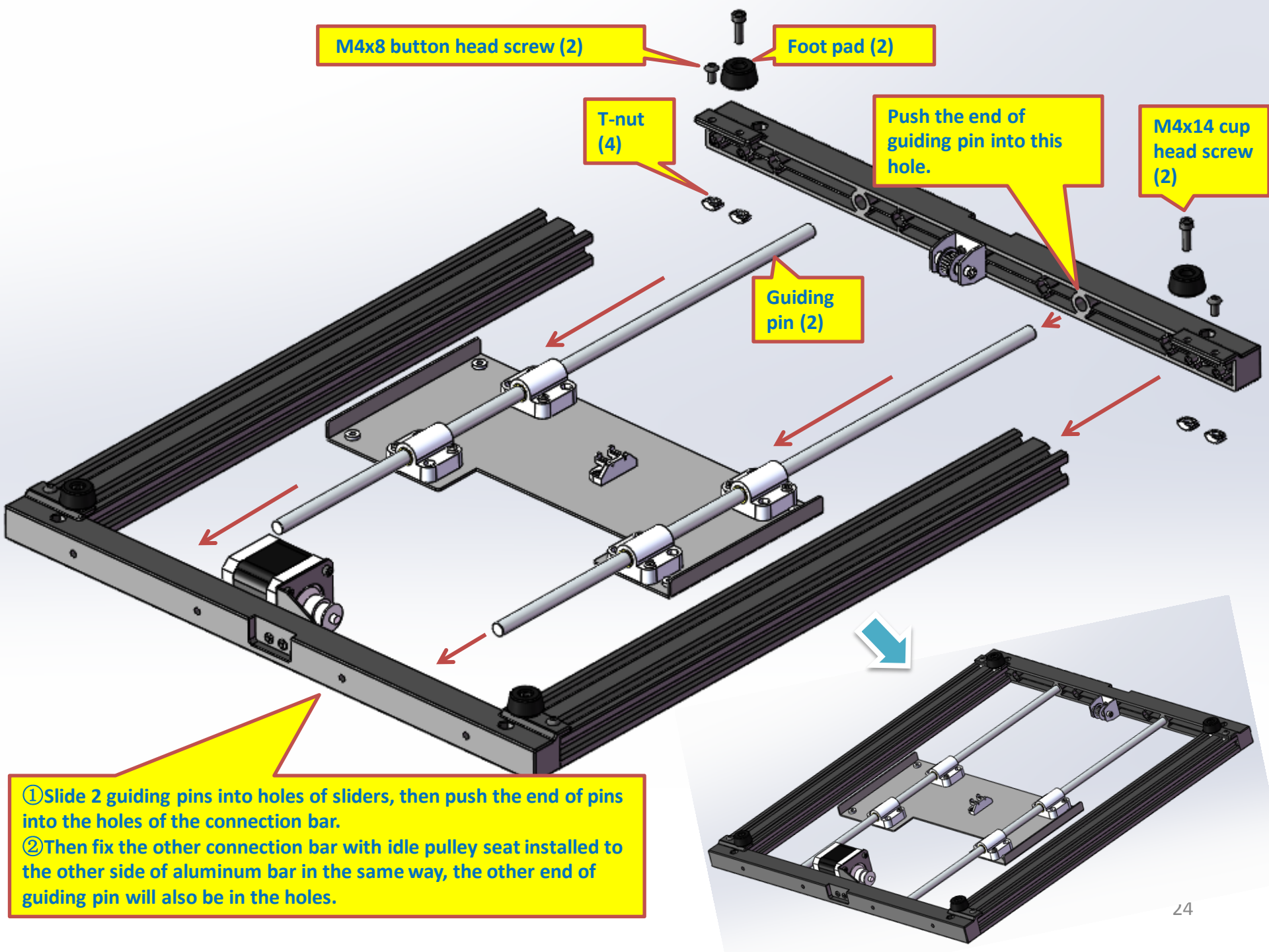

M4x8 button head screw (2)

Foot pad (2)

T-nut (4)

Push the end of guiding pin into this hole.

M4x14 cup head screw (2)

Guiding pin (2)

① Slide 2 guiding pins into holes of sliders, then push the end of pins into the holes of the connection bar.
② Then fix the other connection bar with idle pulley seat installed to the other side of aluminum bar in the same way, the other end of guiding pin will also be in the holes.

2.5 Install timing belt to Y motion system

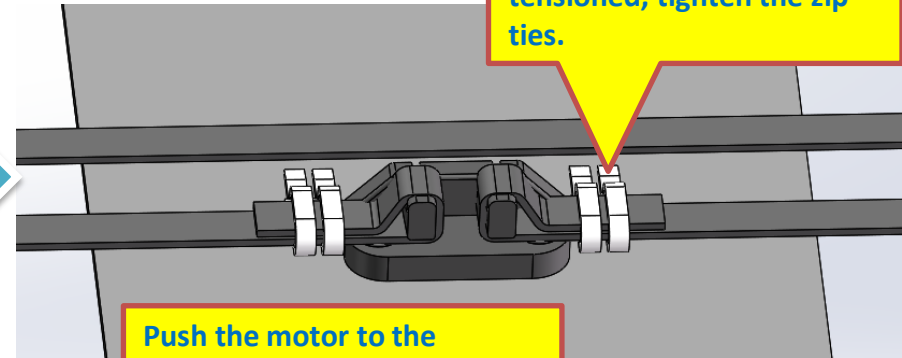
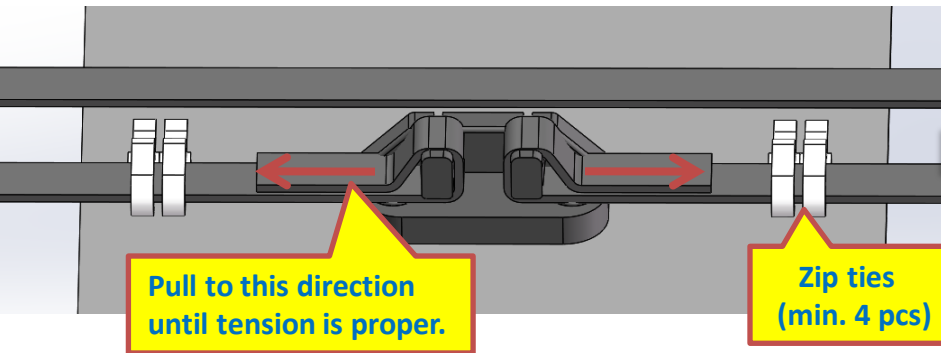
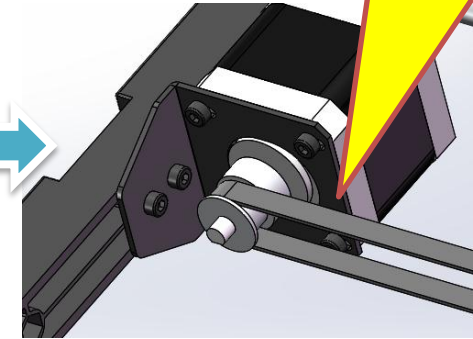
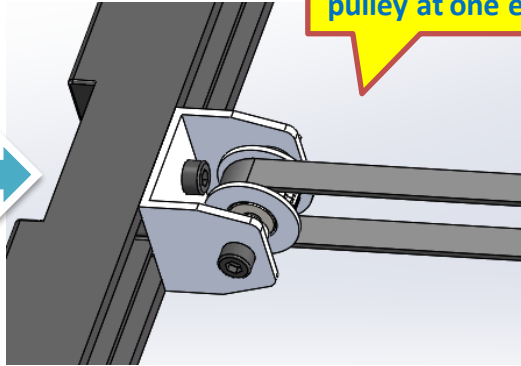
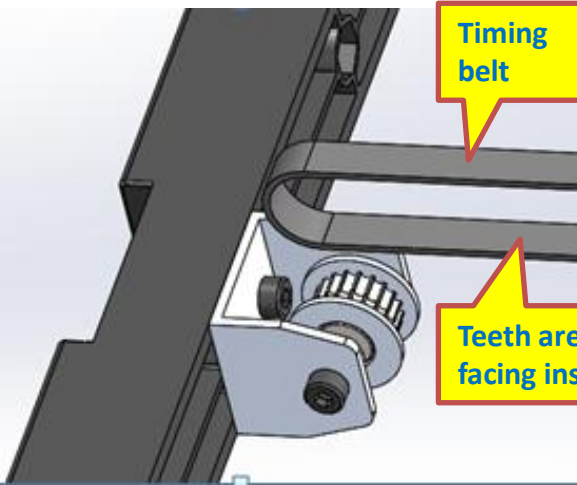

What is proper tension of belt: The upper side and lower side are in parallel. You will get the bounced-back feeling while touching it.

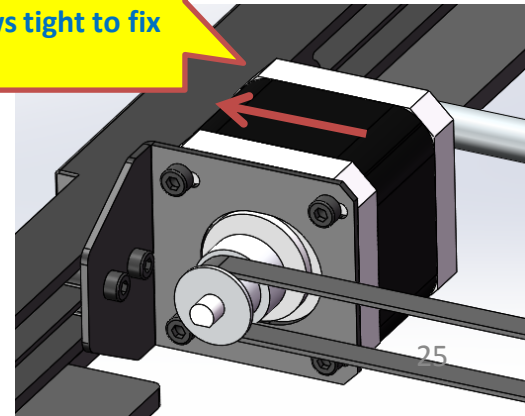
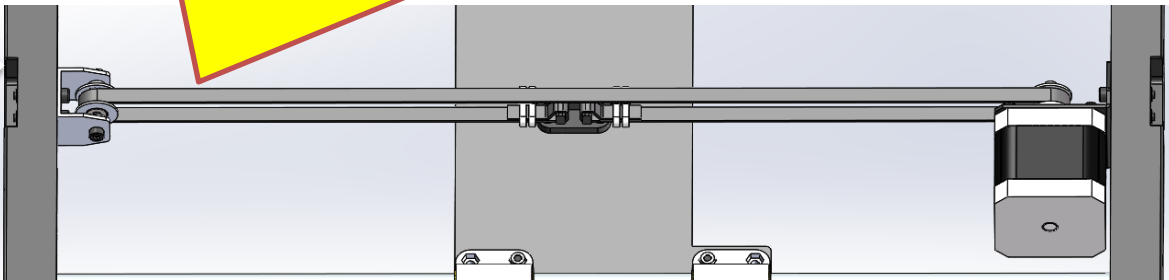

2.6 Fix the PMMA covers

Button head screw M4x8 (4)

PMMA PLATE-B

T-NUT (4)

Attention:
DON'T fully tighten these 8 screws and make sure the platform slides when being pushed by hand.

PMMA PLATE-A

Button head screw M4x25 (4)

M3 lock nut (4)

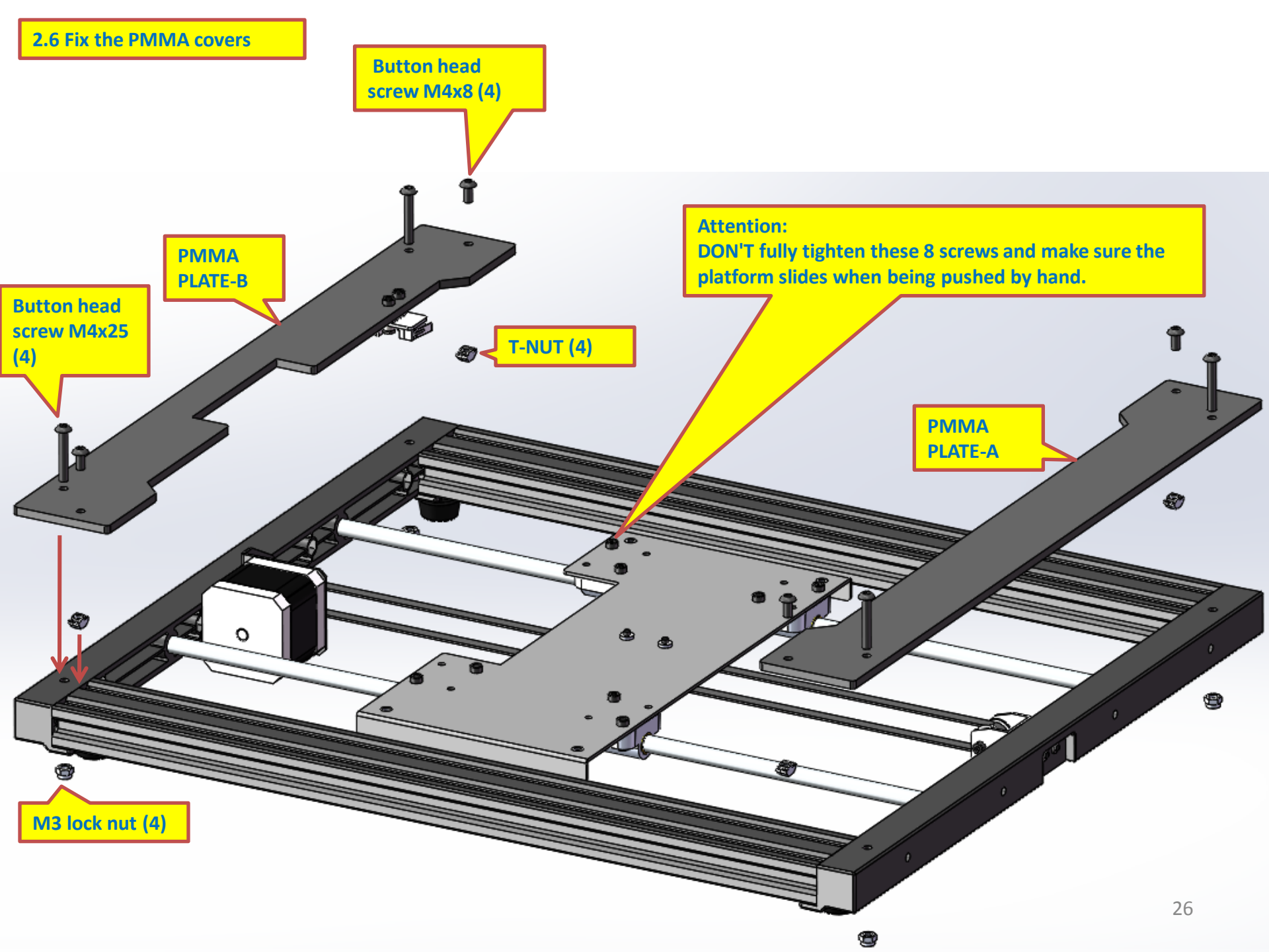

Assembly of Y motion system is complete.

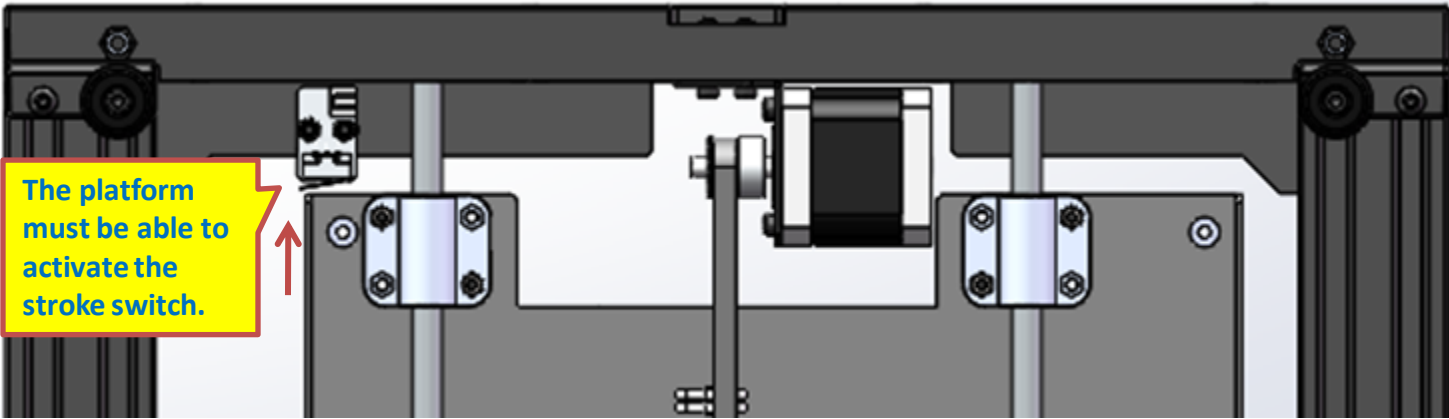

Bottom side

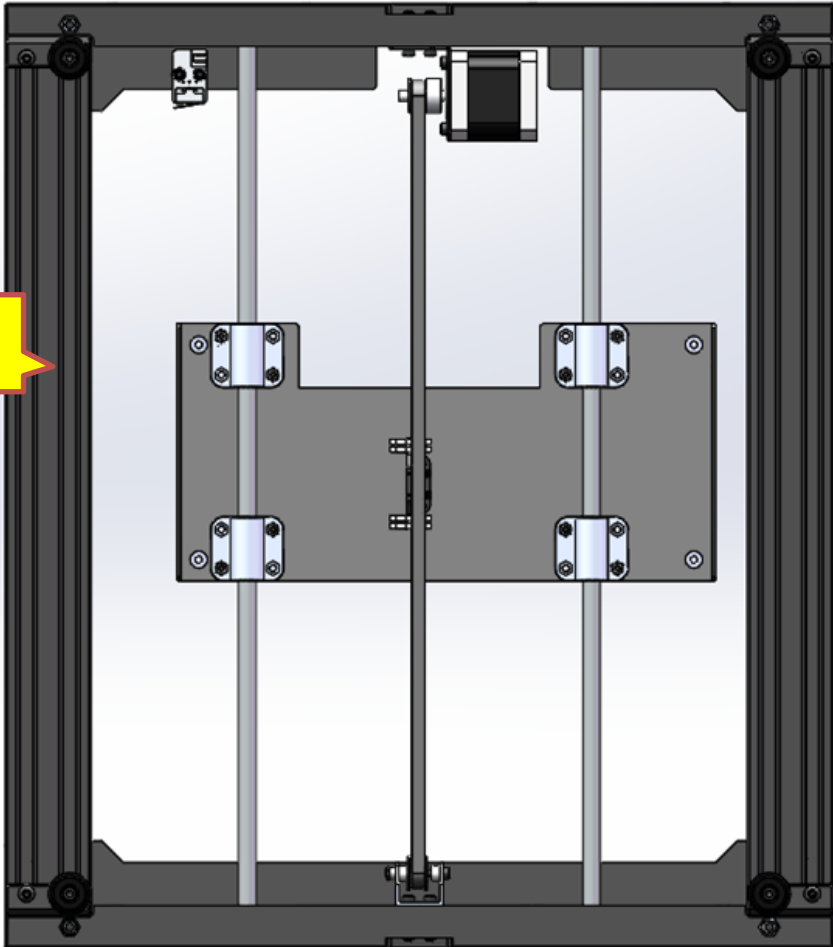

Top side

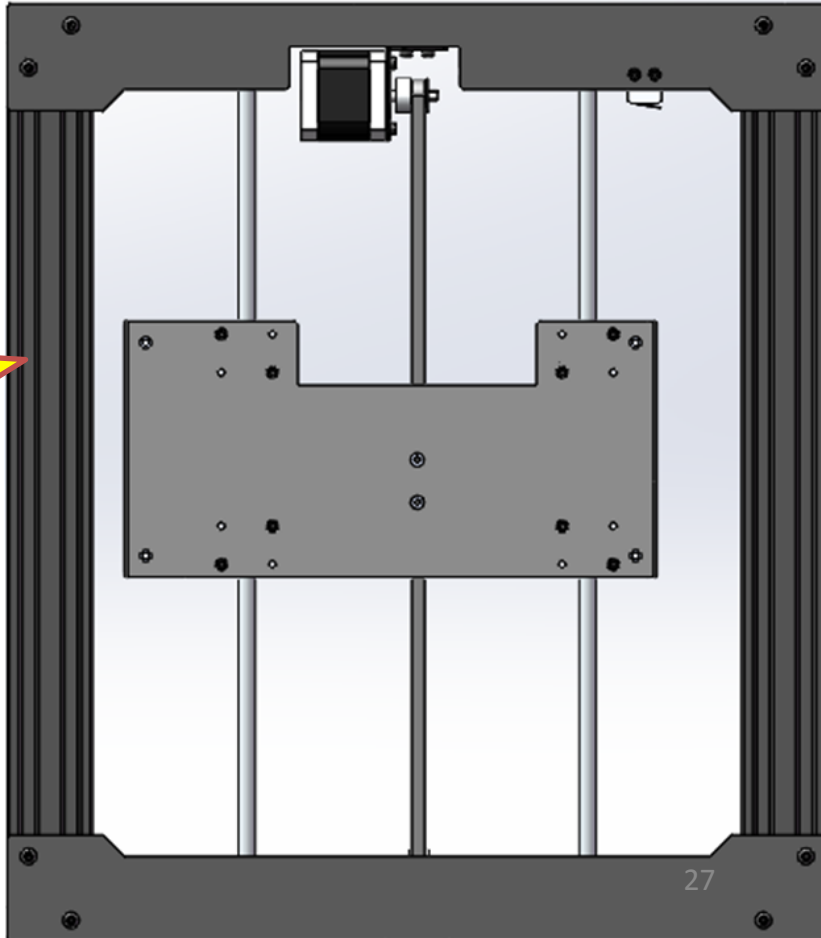

Material list #3:

Sequence	#	Description	QTY	Remark
X motion system	1	Nut assembly	2	Plastic
X motion system	2	Guiding pin	2	
X motion system	3	X motion slider	1	Plastic
X motion system	4	Nylon spacer	1	Height: 2mm
X motion system	5	Nylon spacer	2	Height: 6mm
X motion system	6	Idle pulley for X	1	Sheet steel
X motion system	7	X motion motor seat	1	Sheet steel
X motion system	8	Toothed block	2	Plastic
X motion system	9	Stepper motor stepper motor	1	
X motion system	10	Pulley	1	The one with smaller hole
X motion system	11	Stroke switch stroke switch	1	
X motion system	12	Drive screw	1	Short one
X motion system	13	Drive screw	1	Long one
X motion system	14	Pulley	2	The one with bigger hole
X motion system	15	Bearing	3	
X motion system	16	Washer for drive screw	1	Plastic
X motion system	17	Timing belt	1	The longer open ended one



Attention:

① The open-ended belt with longer length will be used here.

3.1 X motion system assembly

Guiding pin (2)

X motion slider

Nut seat (2)

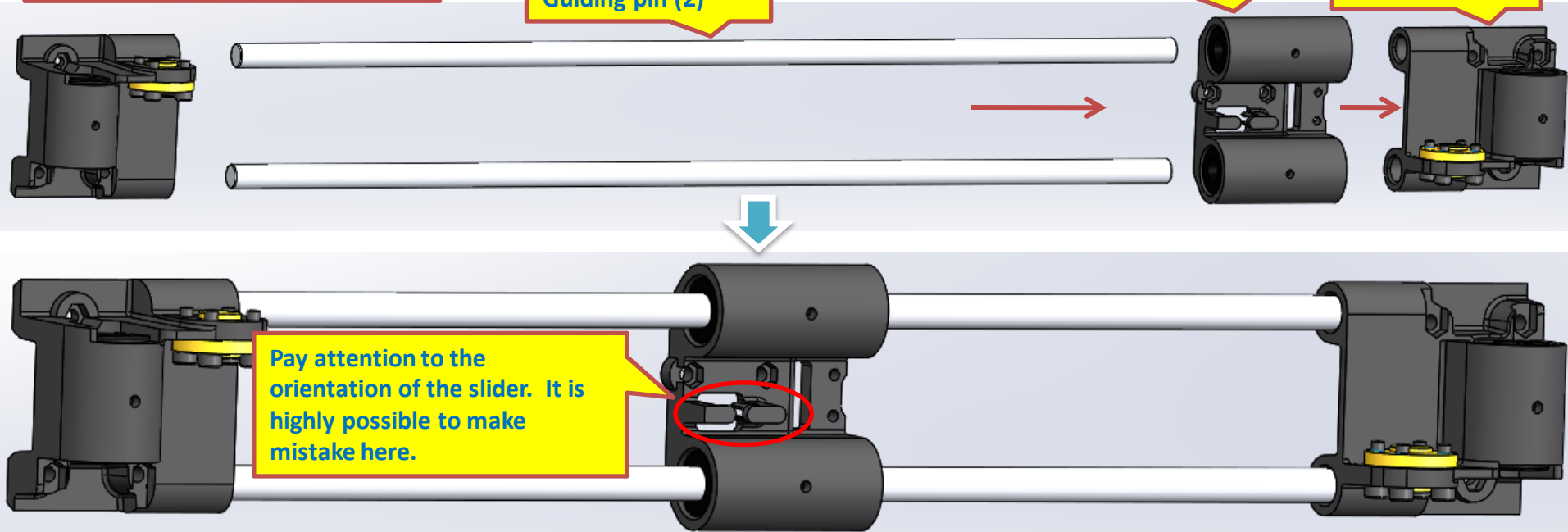

3.2 X motion idle pulley assembly

X pulley seat (black sheet steel)

M3 lock nut

The idle pulley for X motion is NOT symmetrical. Pay attention to its orientation during assembly.

M3x18 cup head screw

Idle pulley

2mm nylon spacer

Attention : DON'T over tighten the screw. When the pulley is touched by hand, it should be able to move smoothly.

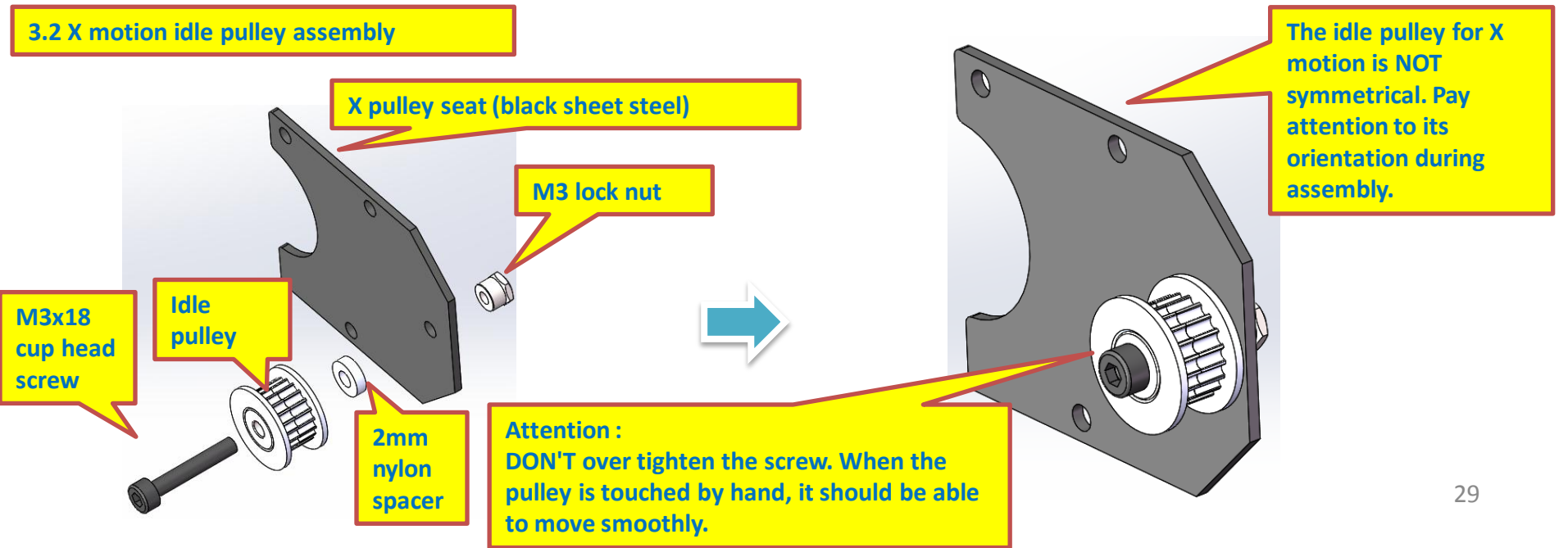

Motor seat for X motion (black sheet steel)

M3x8 cup head screw (2)

M3x14 cup head screw (4)

M3 lock nut (6)

M3x14 cup head screw

M3x8 cup head screw



Pay attention to the orientation as shown below.

30

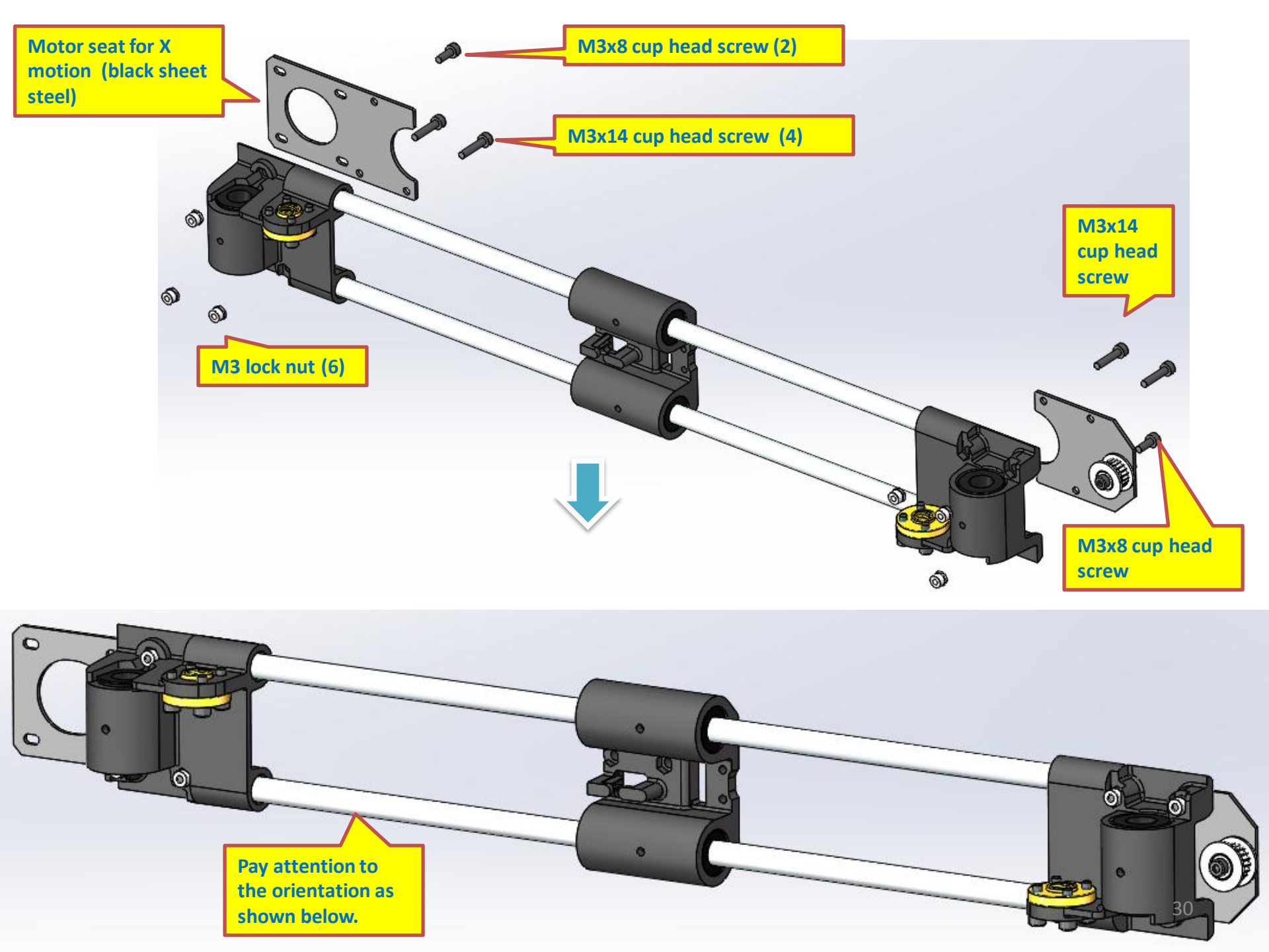

3.3 X motion stroke switch installation

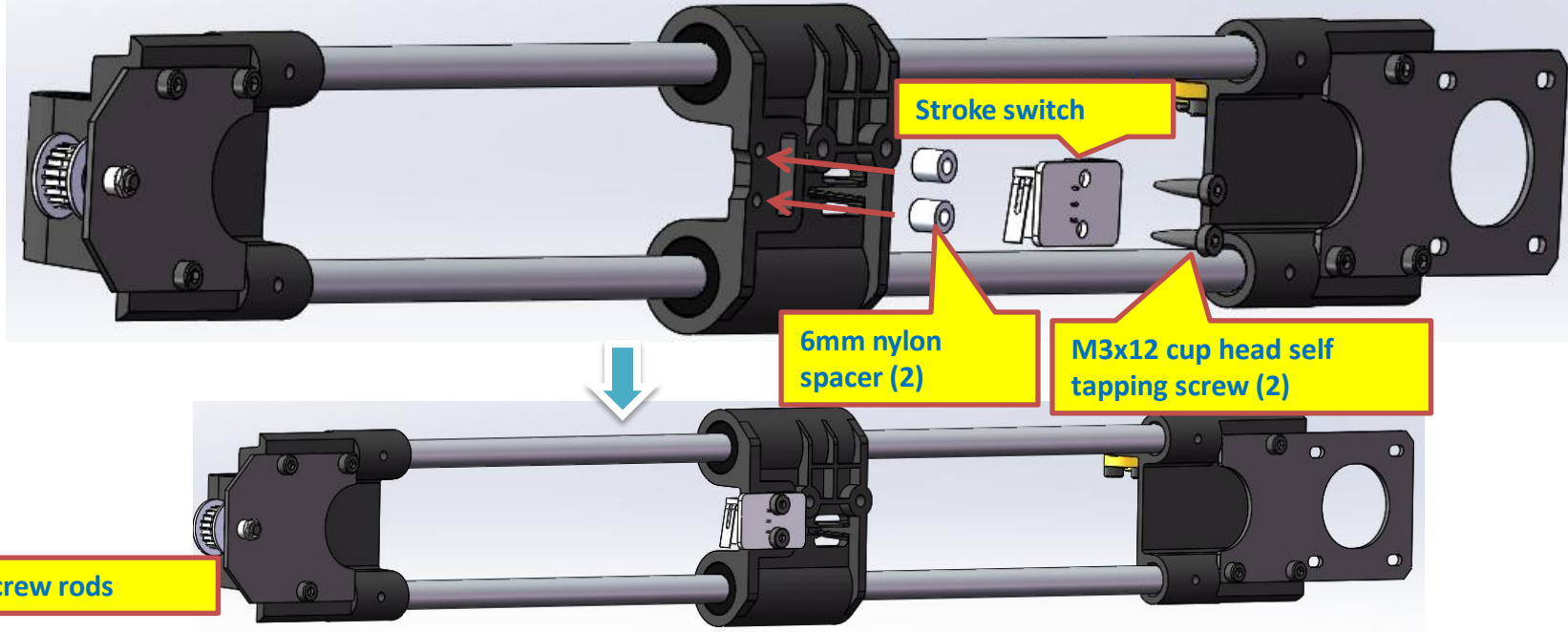

3.4 Assemble the screw rods

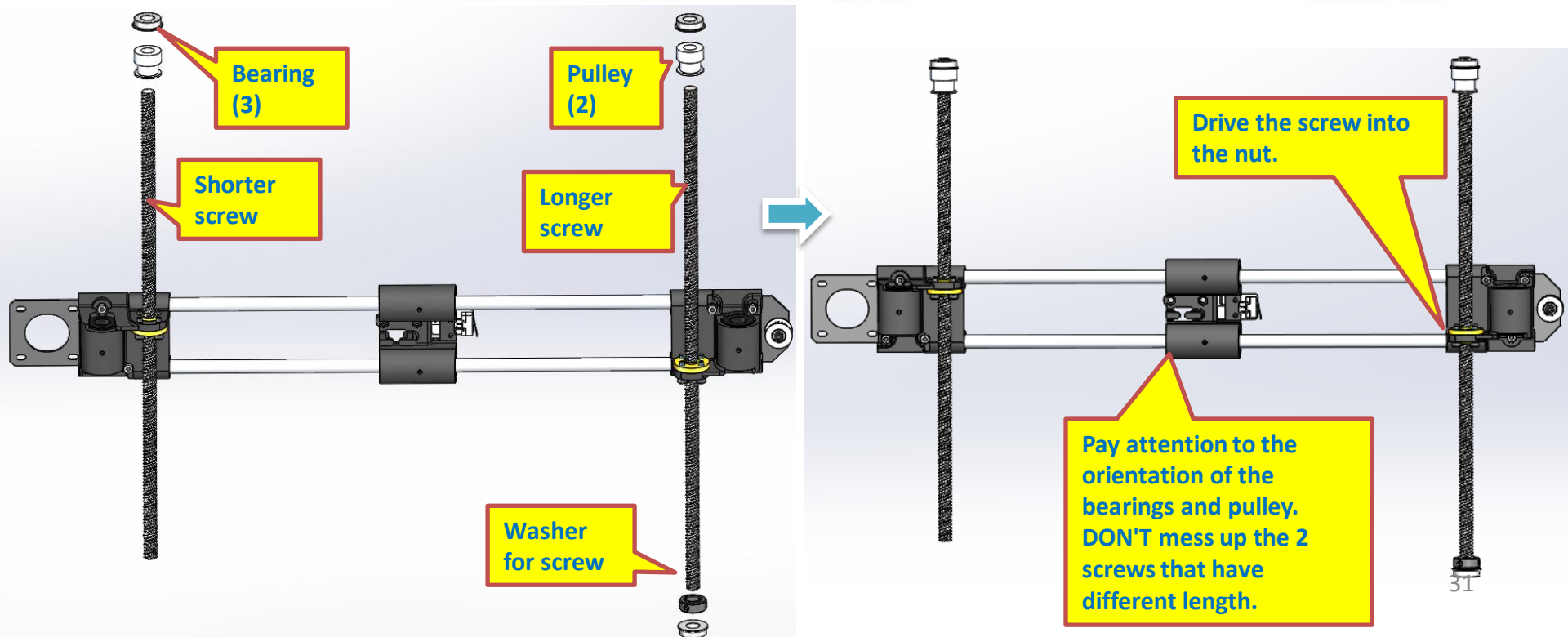

3.5 Install X motion motor

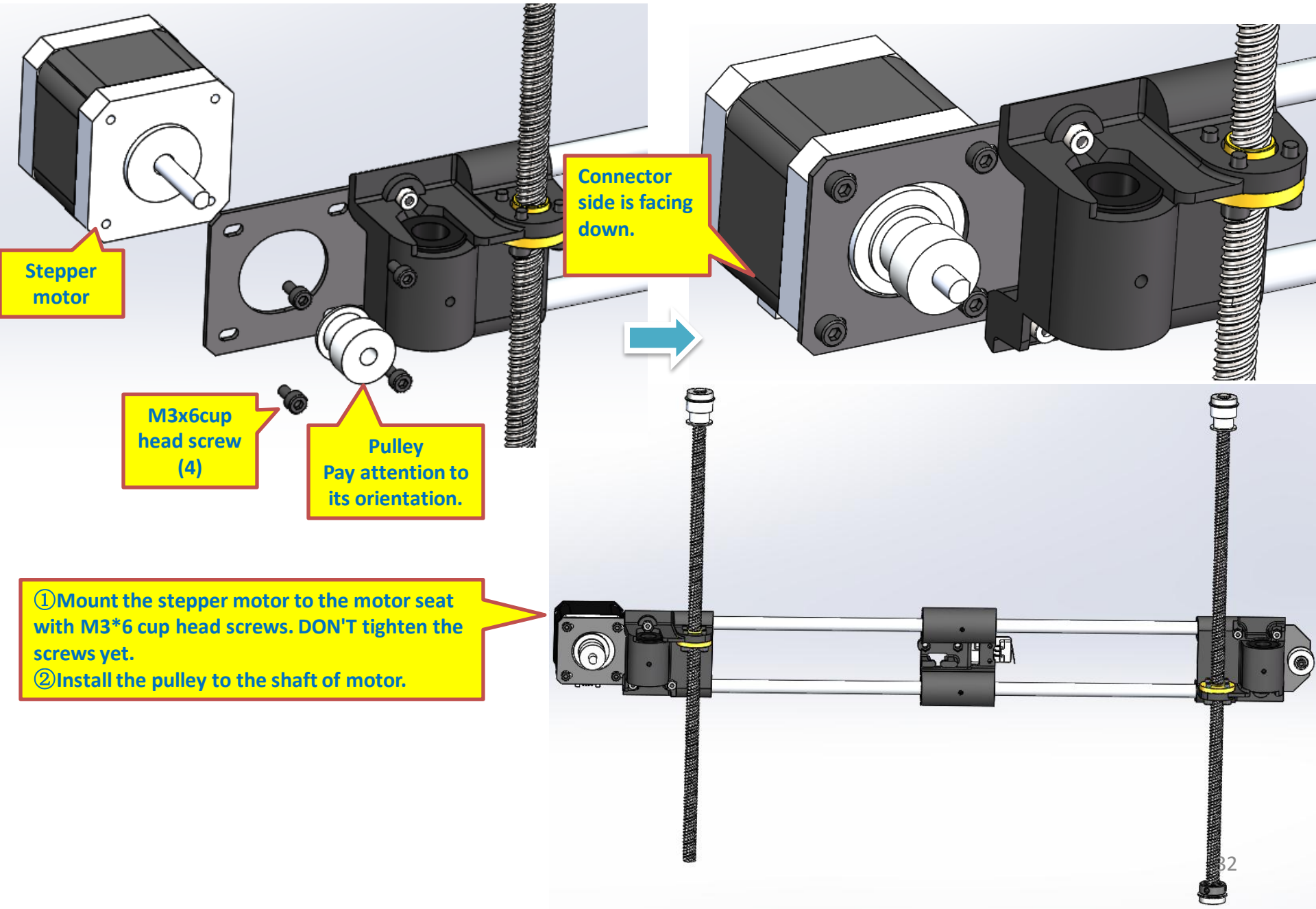

Material list #3

Sequence	#	Description	QTY	Remark
Z motion system assembly	1	Right angle connector	4	Plastic
Z motion system assembly	2	Al profile	2	The shorter one
Z motion system assembly	3	Z motion motor seat	1	Sheet steel
Z motion system assembly	4	Z motion motor seat +	1	Sheet steel
Z motion system assembly	5	Z motor washer	1	PMMA
Z motion system assembly	6	Z motor washer++	1	Glass fiber board
Z motion system assembly	7	Stepper motor	1	
Z motion system assembly	8	Shaft coupler	1	
Z motion system assembly	9	Stroke switch	1	
Z motion system assembly	10	Guiding pin	2	Thicker one with shoulder
Z motion system assembly	11	Timing belt	1	Close ended
Z motion system assembly	12	Connection bar	1	Plastic
Z motion system assembly	13	Z motion transmission plate	1	PMMA
Z motion system assembly	14	Belt adjustment piece	1	PMMA
Z motion system assembly	15	Z fixation plate	1	PMMA
Z motion system assembly	16	Nylon spacer	1	4mm high
Z motion system assembly	16	Base with teeth	2	Plastic

Attention:

- ① Use the shorter aluminum profiles for this step.
- ② Use the thicker and shouldered guiding pins.
- ③ The timing belt is close ended.



4.1 Assembly Z motion motor assembly

①:

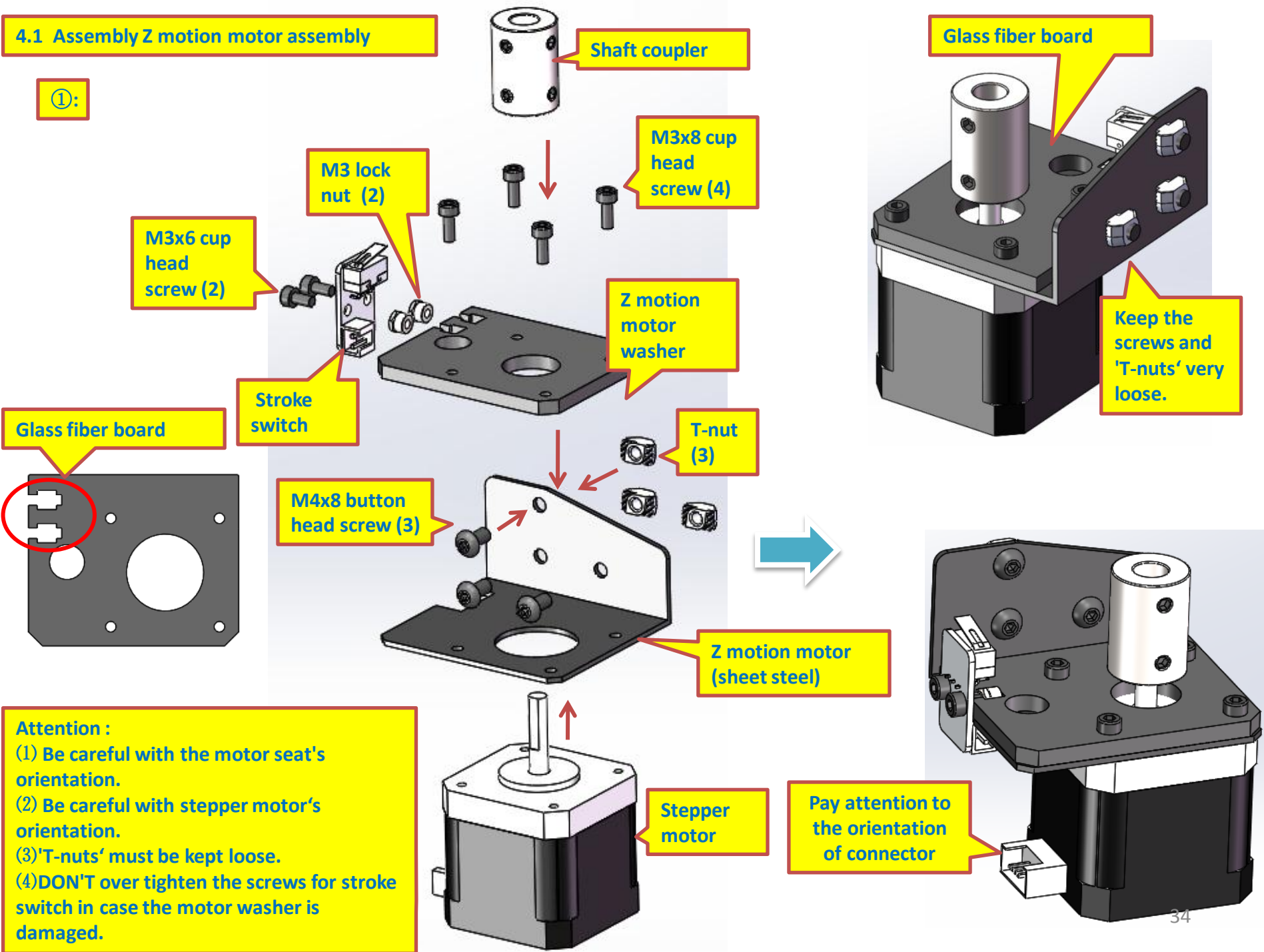

②:

Attention :

- (1) Be careful with the motor seat's orientation.
- (2) Be careful with stepper motor's orientation.
- (3) 'T-nuts' must be kept loose.

M3x8 cup head screw (4)

Z motion motor washer

T-nut (3)

Keep 'T-nut' NOT tightened.

M4x8 button head screw (3)

Z motion motor seat+ (sheet steel)

M3 lock nut (4)

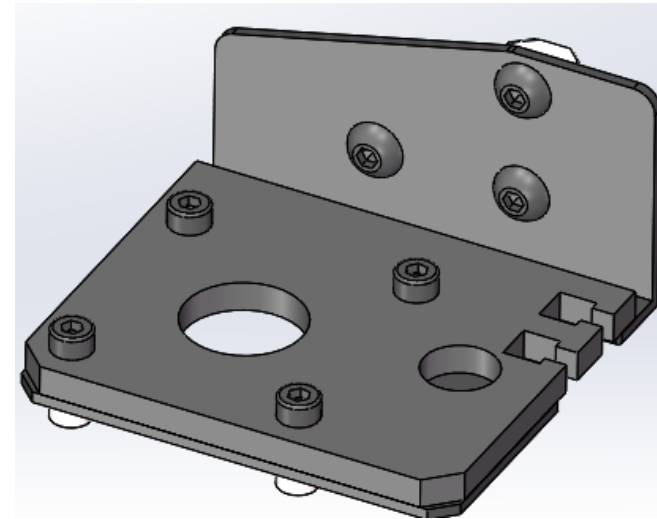
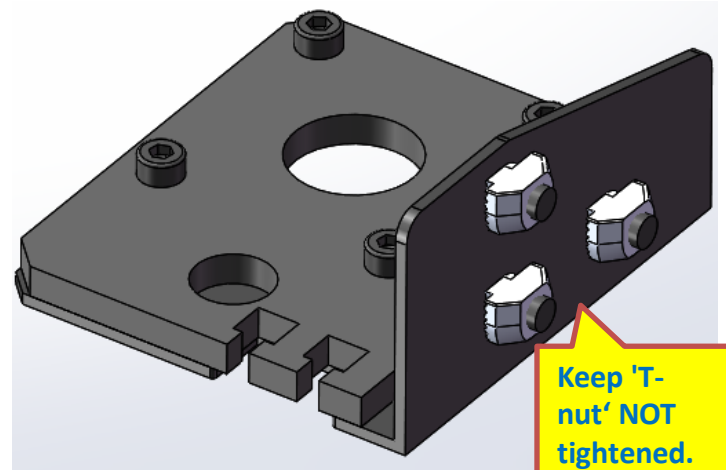

**4.2 Prepare for right angle connector
(4 pcs)**

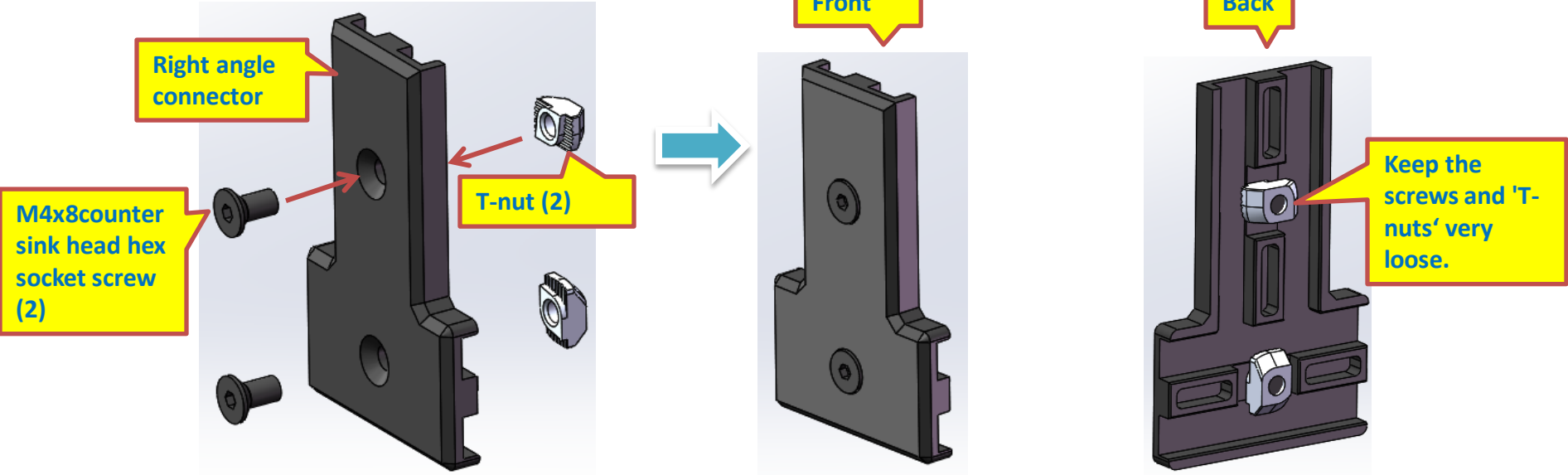

4.3 Install belt adjustment piece

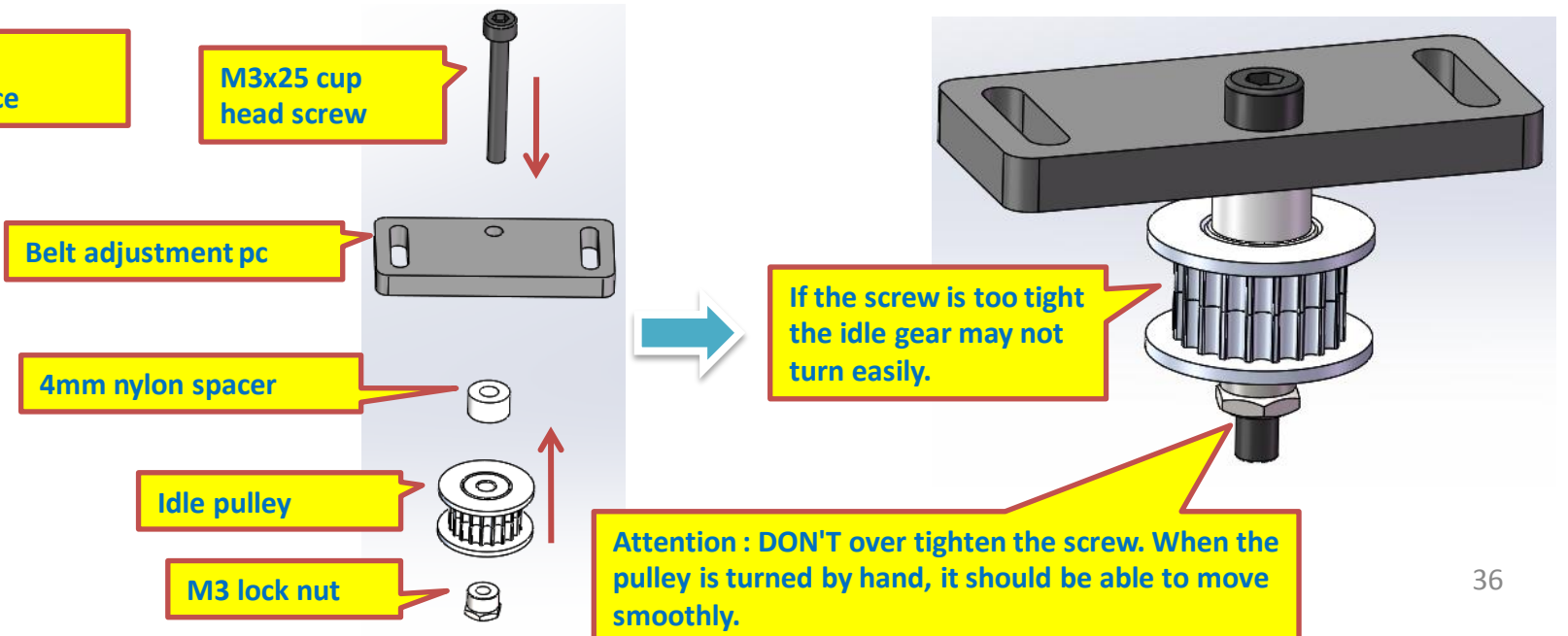

M3x12 cup head screw

Z transmission plate

Belt adjustment piece assembly

M3 lock nut (4)

Check the orientation of Z transmission plate.

Attention :

- (1) Z transmission plate must be installed in correct orientation.
- (2) Belt adjustment piece must be installed in correct orientation.
- (3) 'M3x12 cup head screw' must be kept loose at this step.

The belt adjustment assembly can be moved up or down by sliding this component.

4.4 Install the frame (profiles) for Z motion

Aluminum profile (2)

Right angle connector (2)

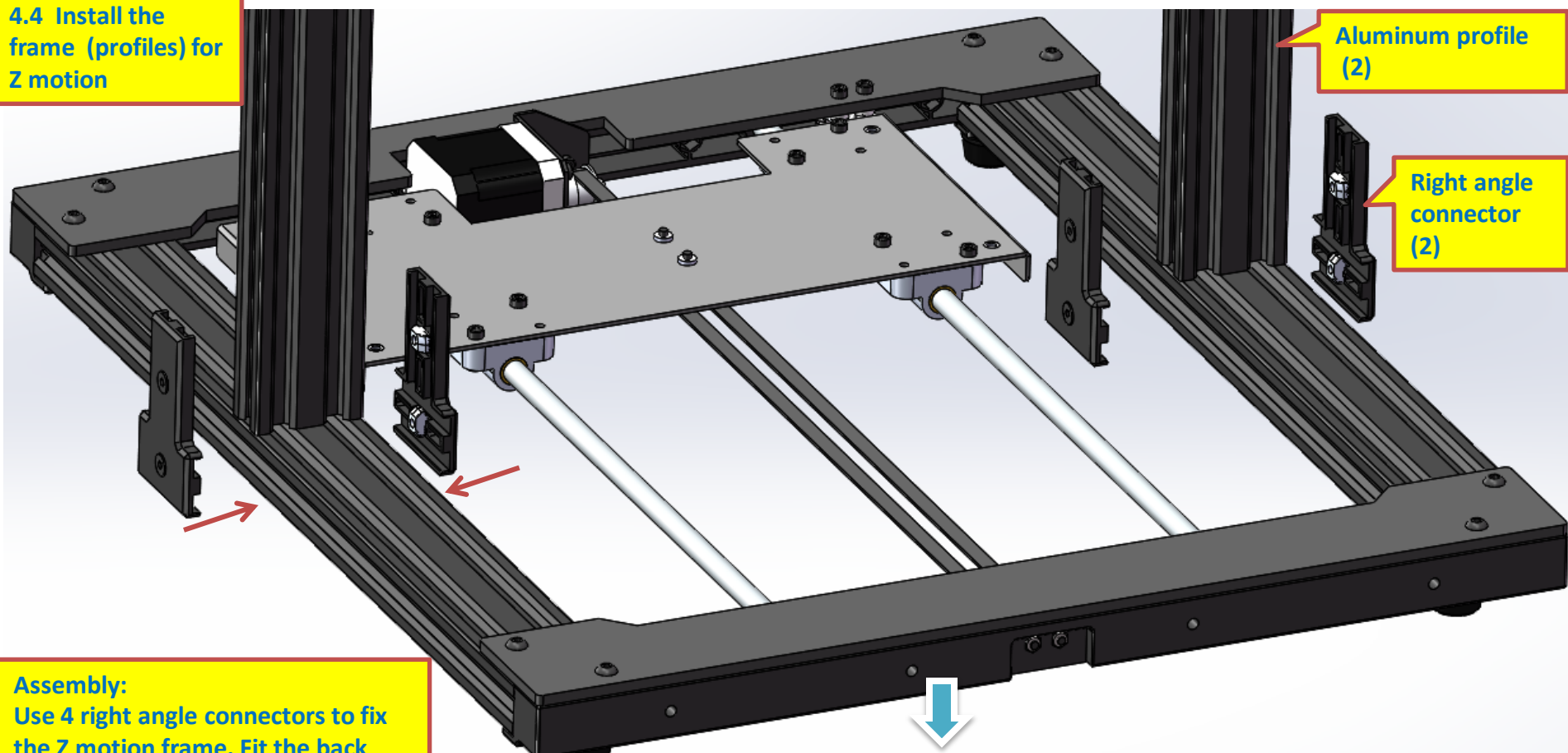

Assembly:
Use 4 right angle connectors to fix the Z motion frame. Fit the back side features of the connectors correctly to the slots of the profile.

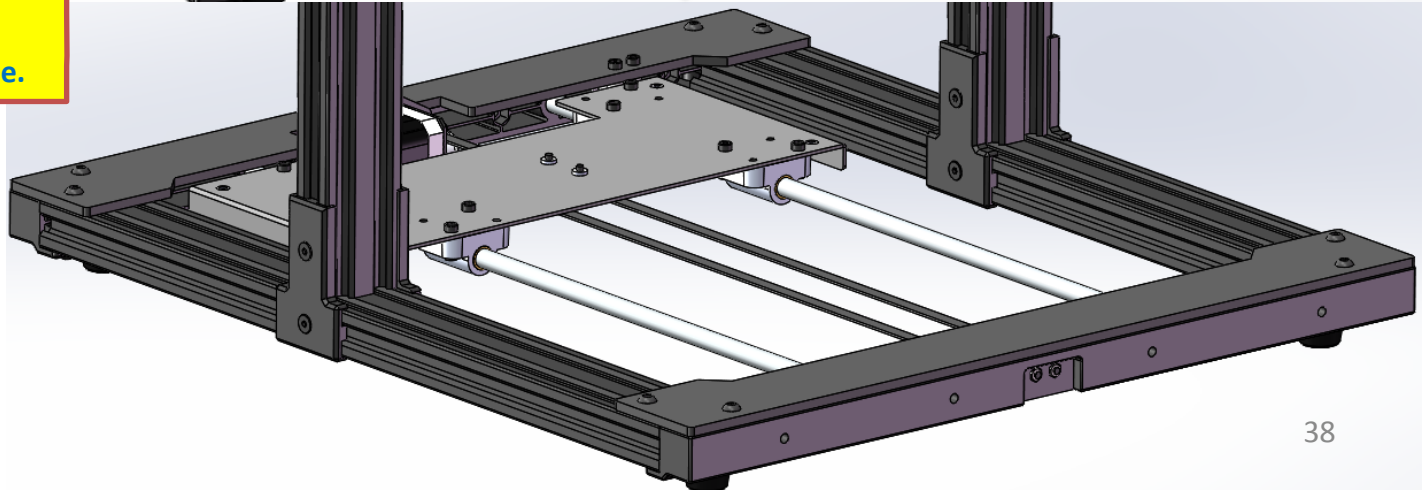

Positioning of Z motion system

Distance:
224mm

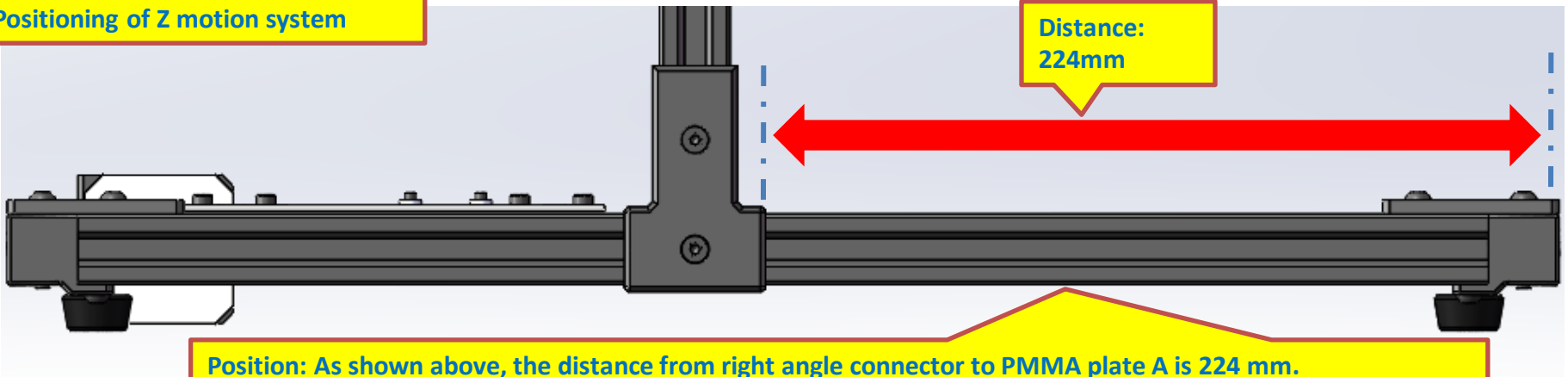

Position: As shown above, the distance from right angle connector to PMMA plate A is 224 mm.

Methods to measure: ① Use a ruler;

② Use the platform top glass (220x240x3 mm) plus any of the PMMA part. (4 mm thick) to get 224 mm to measure.

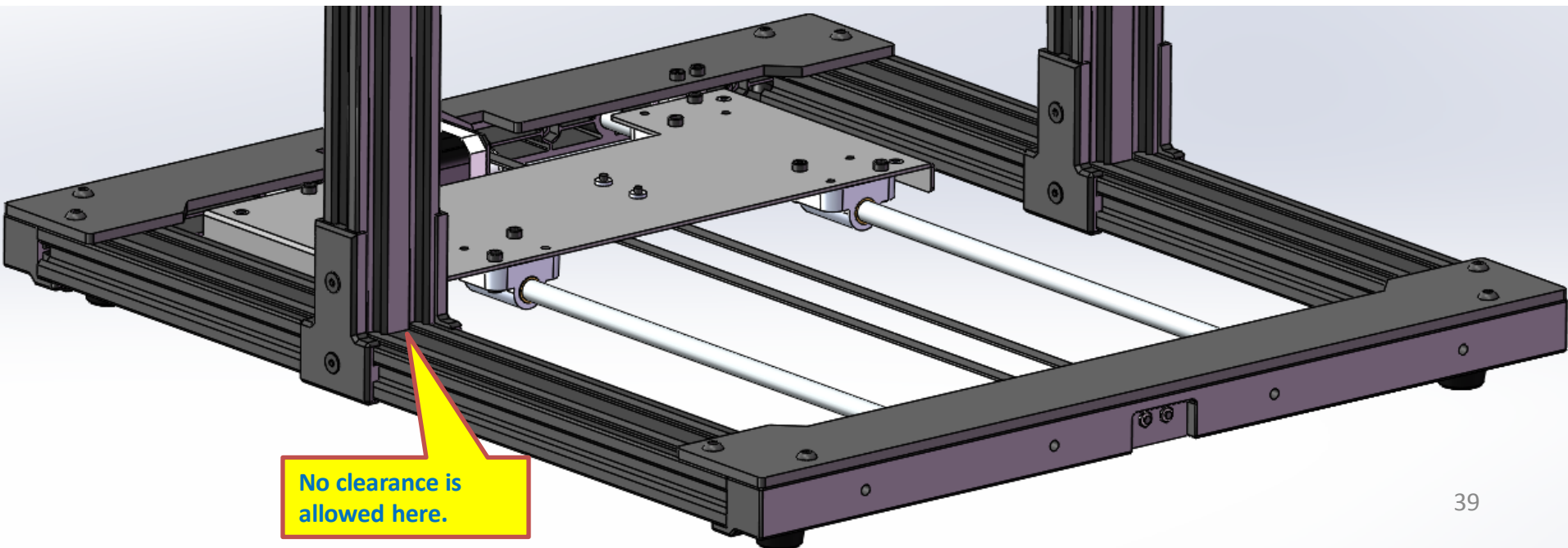

No clearance is
allowed here.

4.5 Install Z motion motor

Mount the pre-assembled Z motor assembly ① to the profile.

Mount the pre-assembled Z motor assembly ② to the profile.

The edge of sheet steel part needs to cling to the top of right angle connector.

Notes:

- (1) Pay attention to the **ORIENTAION** of the motor on the Z axis per the fig.
- (2) The lower side of sheet steel part of motor assemblies must cling closely to the top side of right angle connectors.

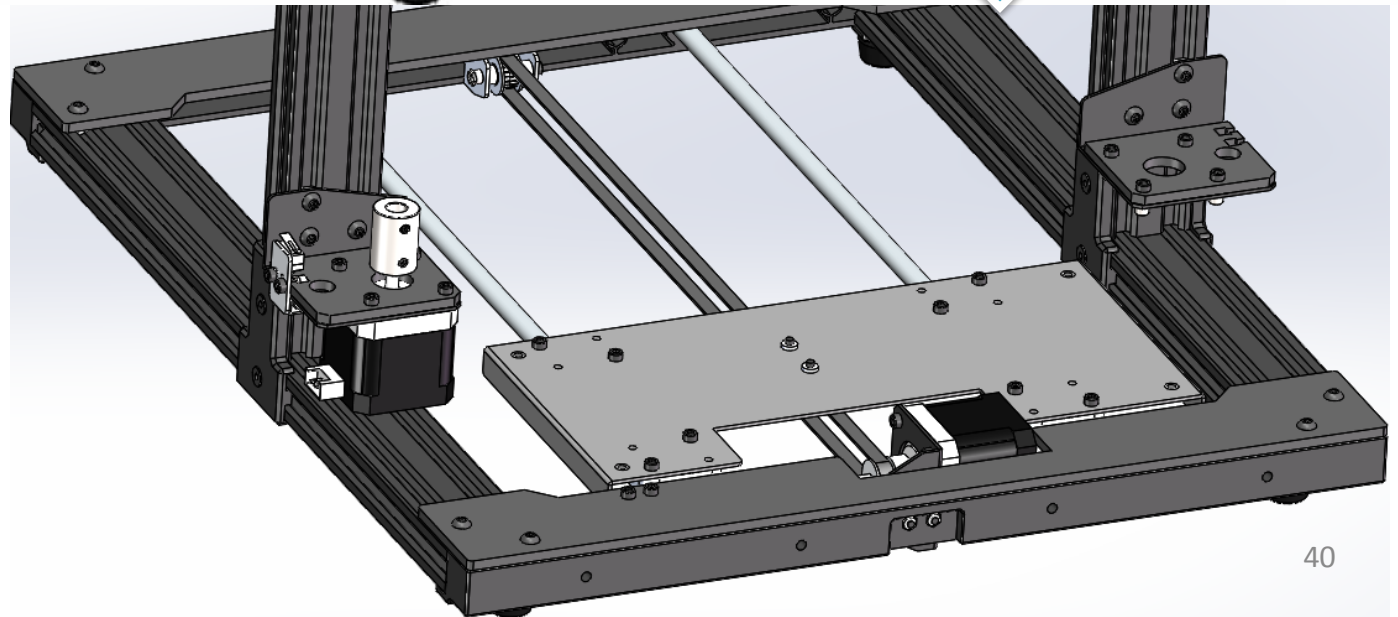
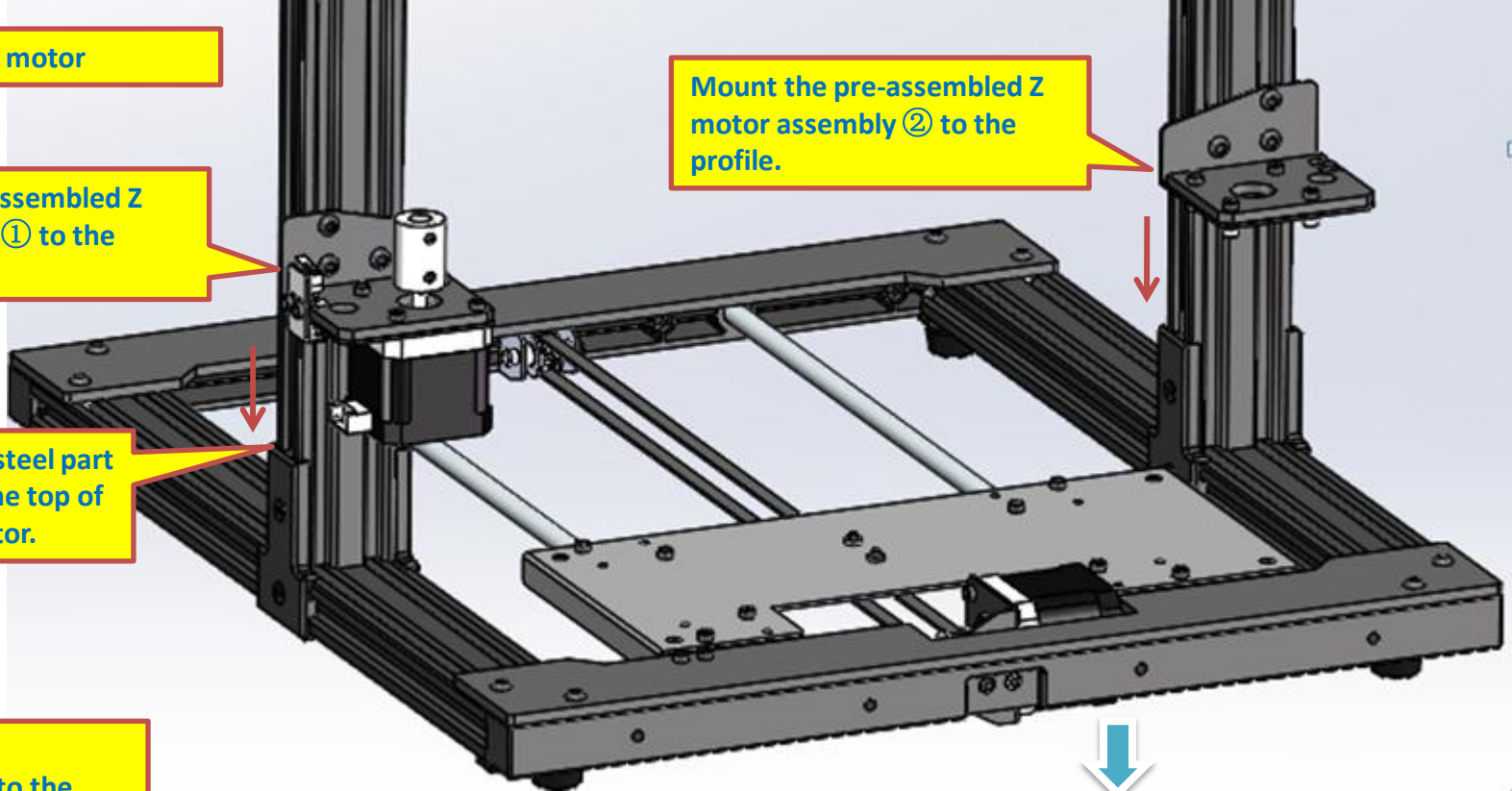

①:

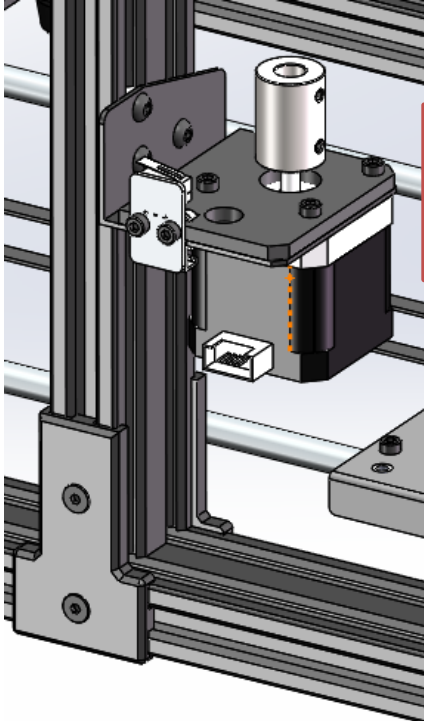

M4x8
button
head screw
(3)

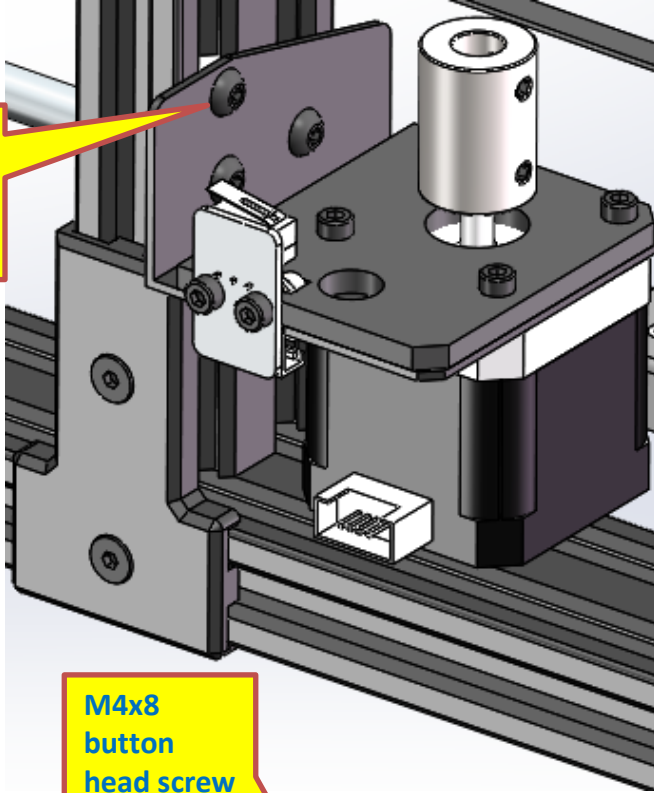

M4x8
button
head screw
(3)

Secure assemblies ①
and ② to aluminum
profiles with pre-
assembled M4x8
button head screws
and 'T-nuts'.

②:

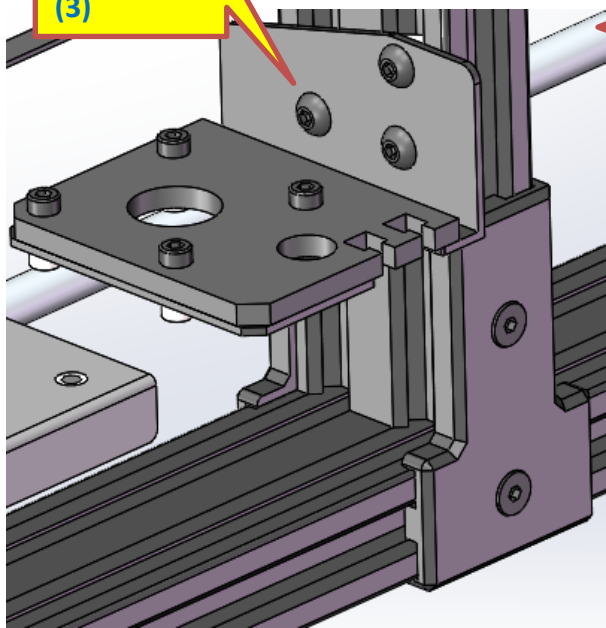
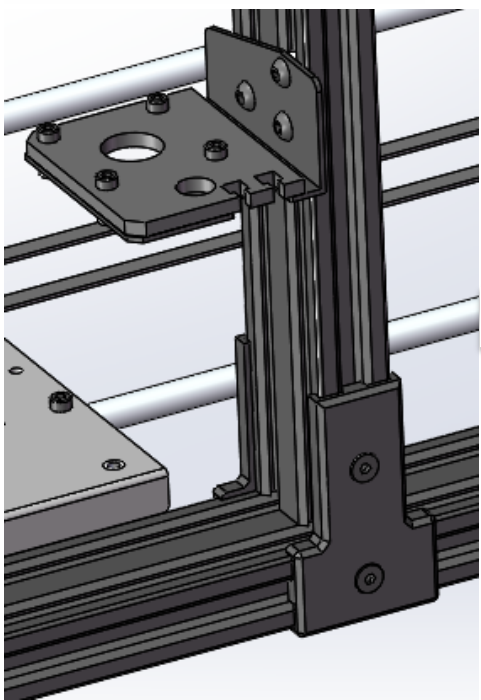

4.6 Z motion system connection bar installation

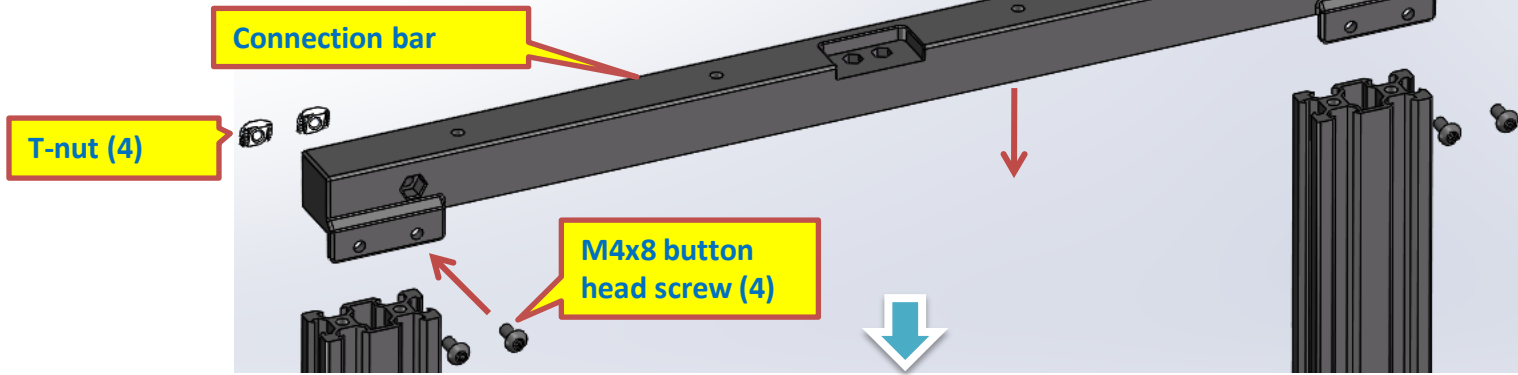

Check the picture at right side for orientation of components installed.

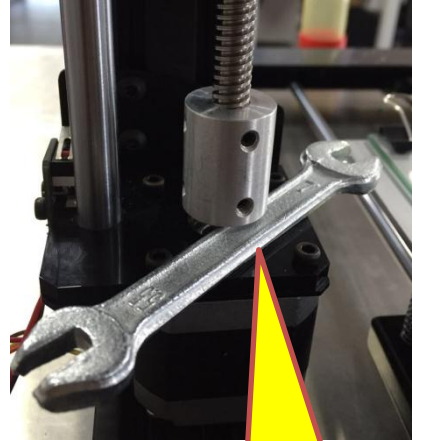
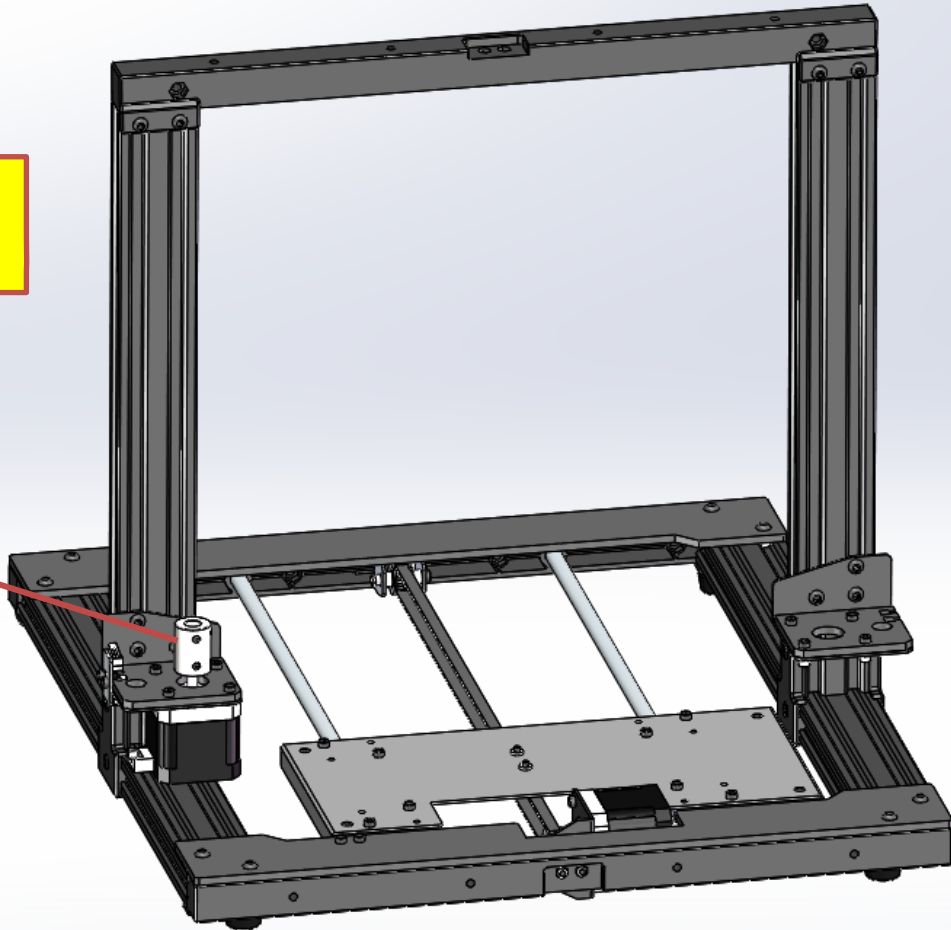
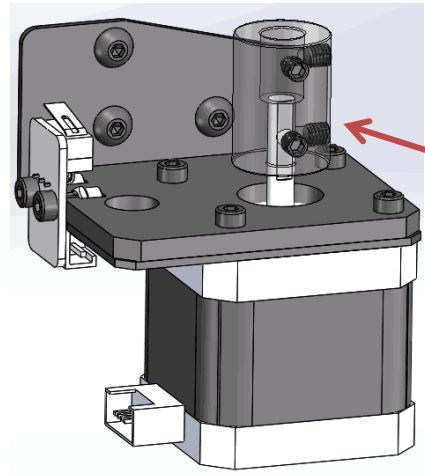

The distance from shaft coupler to the bottom is about the thickness of the wrench.

4.7 Install the cover plates for Z motion system

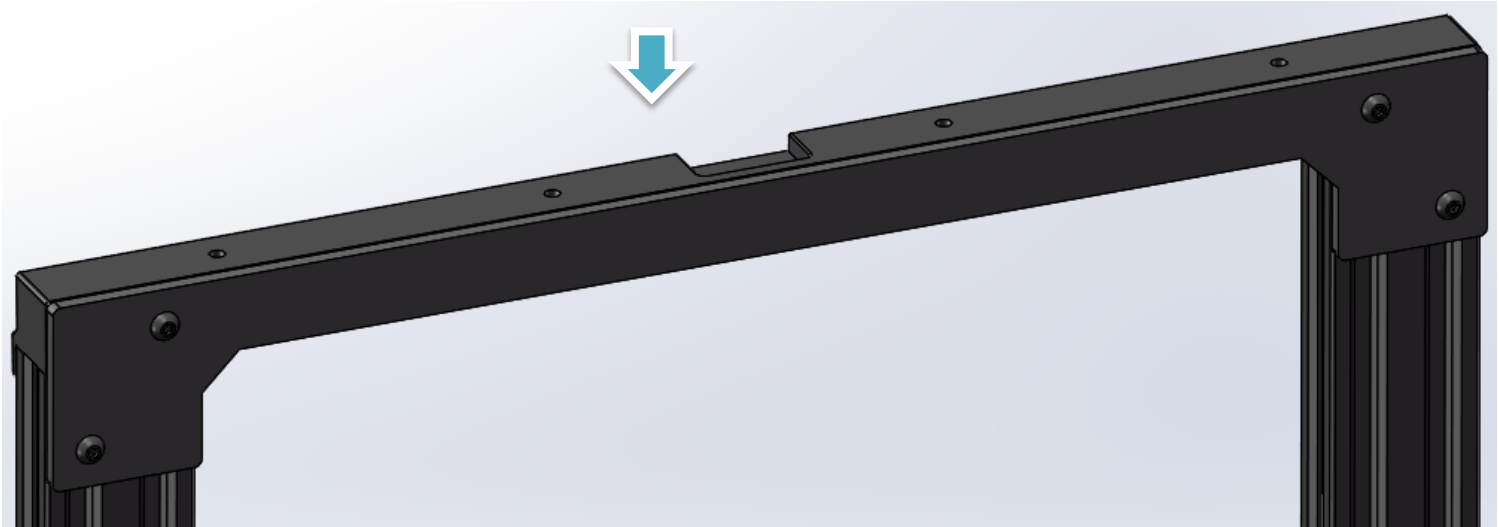
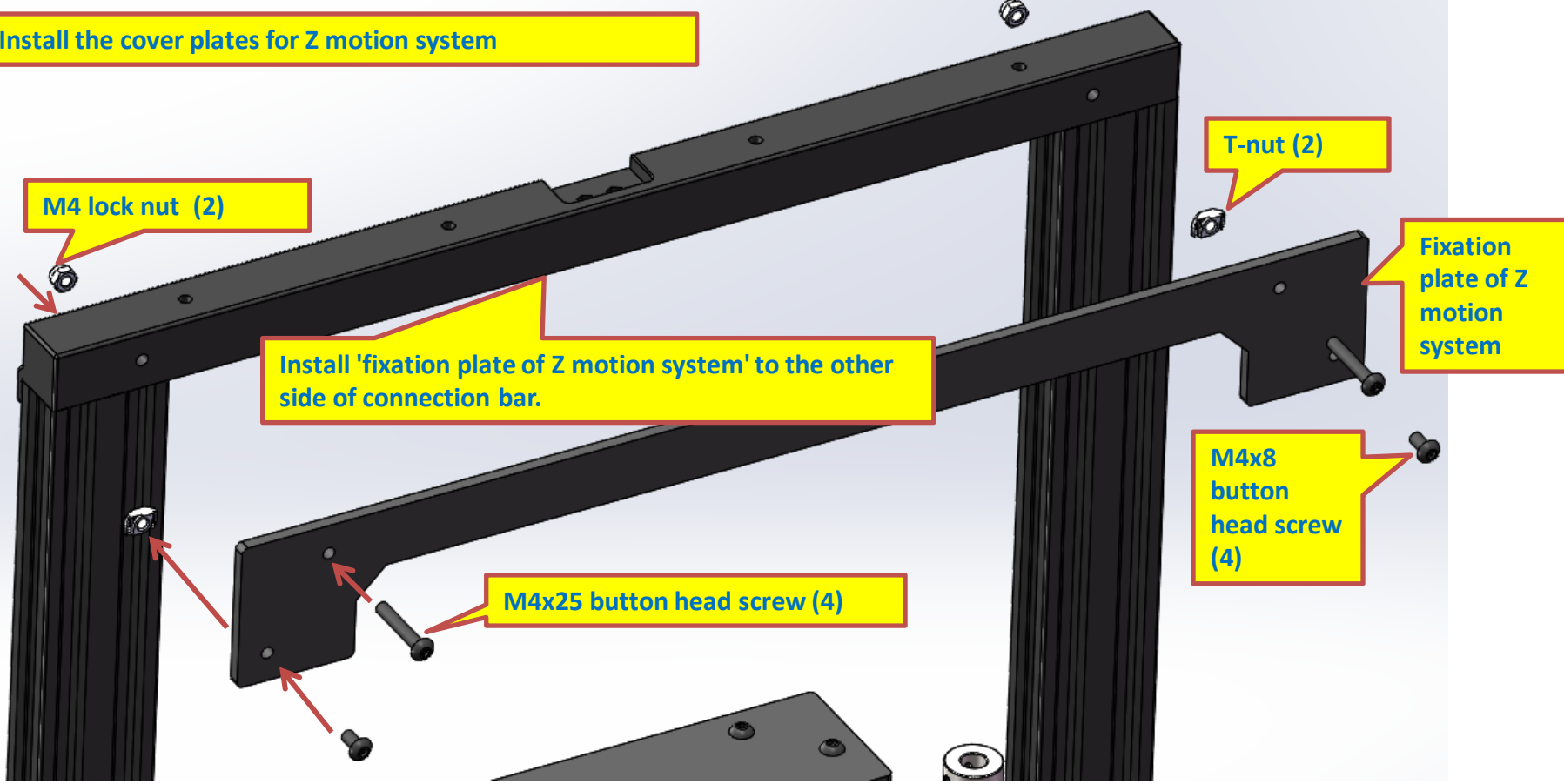

4.8 Install the screw rods

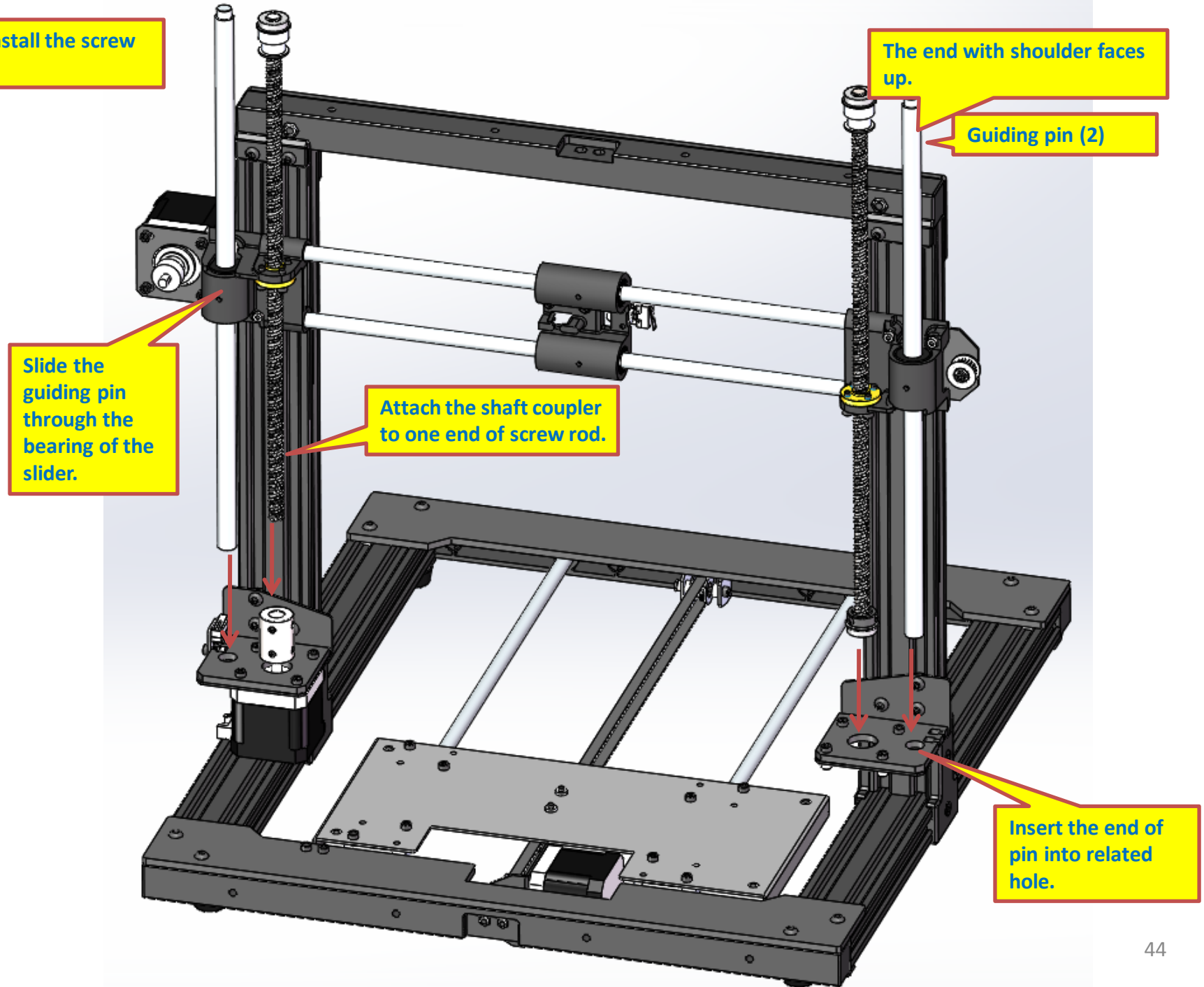

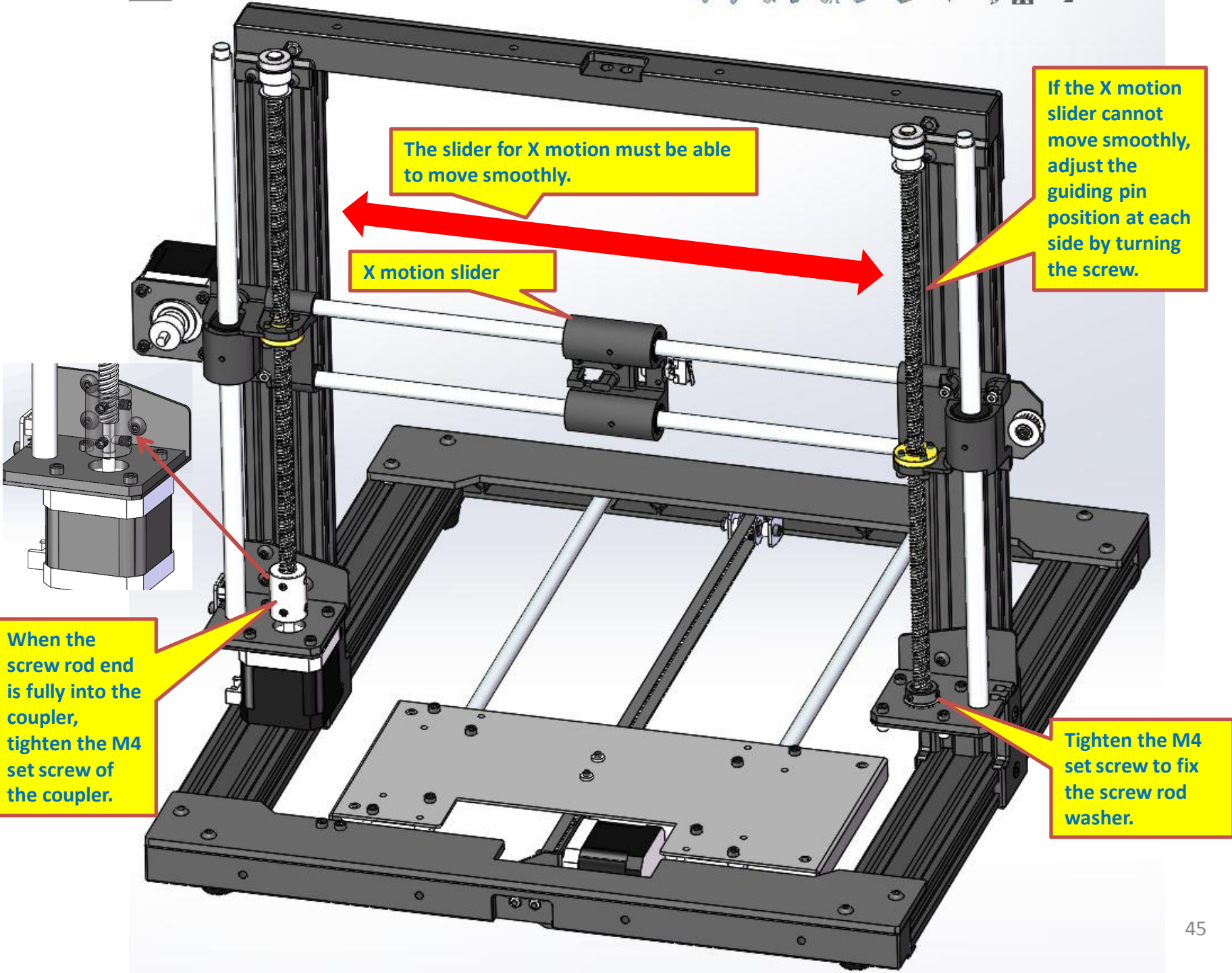

The slider for X motion must be able to move smoothly.

X motion slider

If the X motion slider cannot move smoothly, adjust the guiding pin position at each side by turning the screw.

When the screw rod end is fully into the coupler, tighten the M4 set screw of the coupler.

Tighten the M4 set screw to fix the screw rod washer.

4.9 Install the Z motion timing belt

M4x25 button head screw (4)

Z motion transmission assembly

M4 lock nut (4)

Close ended timing belt

Add tension to the belt by sliding the belt adjustment piece . When tension is proper, fix the adjustment piece by fastening the M3*12 cup head screw.

Material list #4:

Sequence	#	Description	QTY	Remark
Hot end assembly	1	Heat sink	1	Aluminum
Hot end assembly	2	Extrusion motor	1	Motor
Hot end assembly	3	Heat sensor	1	Wire
Hot end assembly	4	Heater	1	Wire
Hot end assembly	5	Throat	1	
Hot end assembly	6	Bigger fan	1	
Hot end assembly	7	Smaller fan	1	
Hot end assembly	8	Nozzle assembly	1	
Hot end assembly	9	Connection plate	1	Sheet steel
Hot end assembly	10	Timing belt	1	Open ended one with longer length

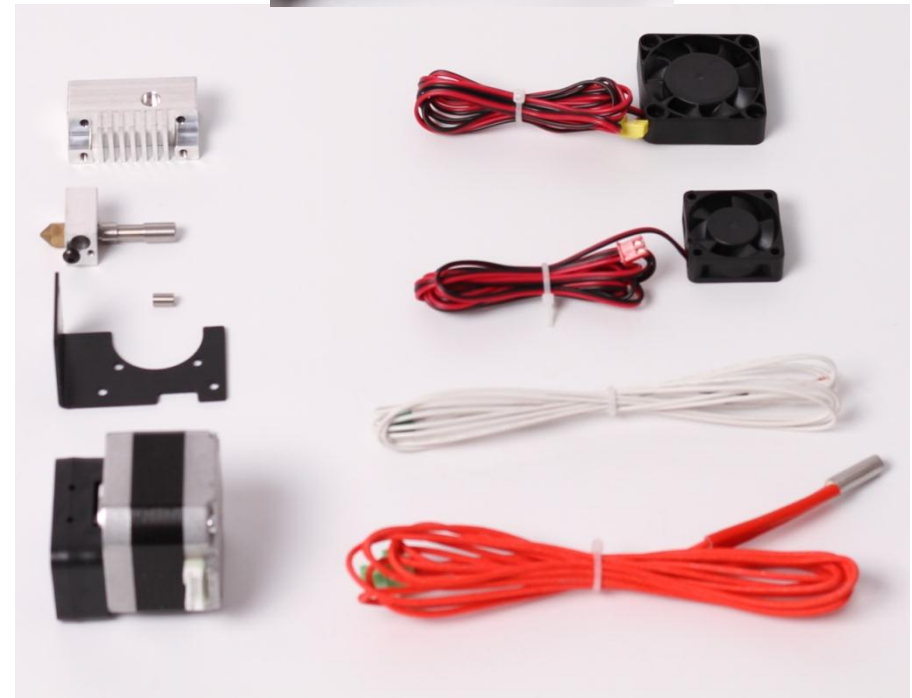

Attention:

①The open ended belt with shorter length will be used here.

5.1 Assemble the smaller cooling fan

Wires out

Air is in to the side without shoulder.

Air is out from the side having shoulder.

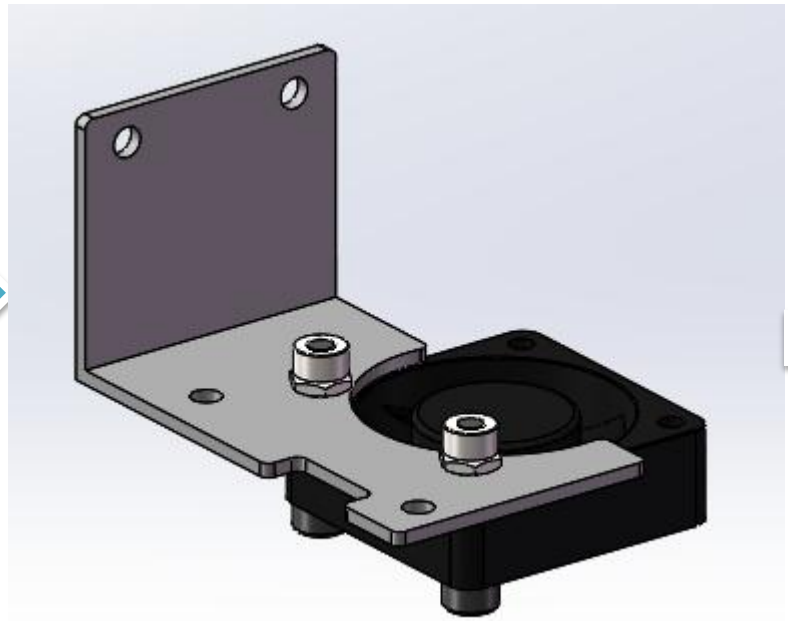
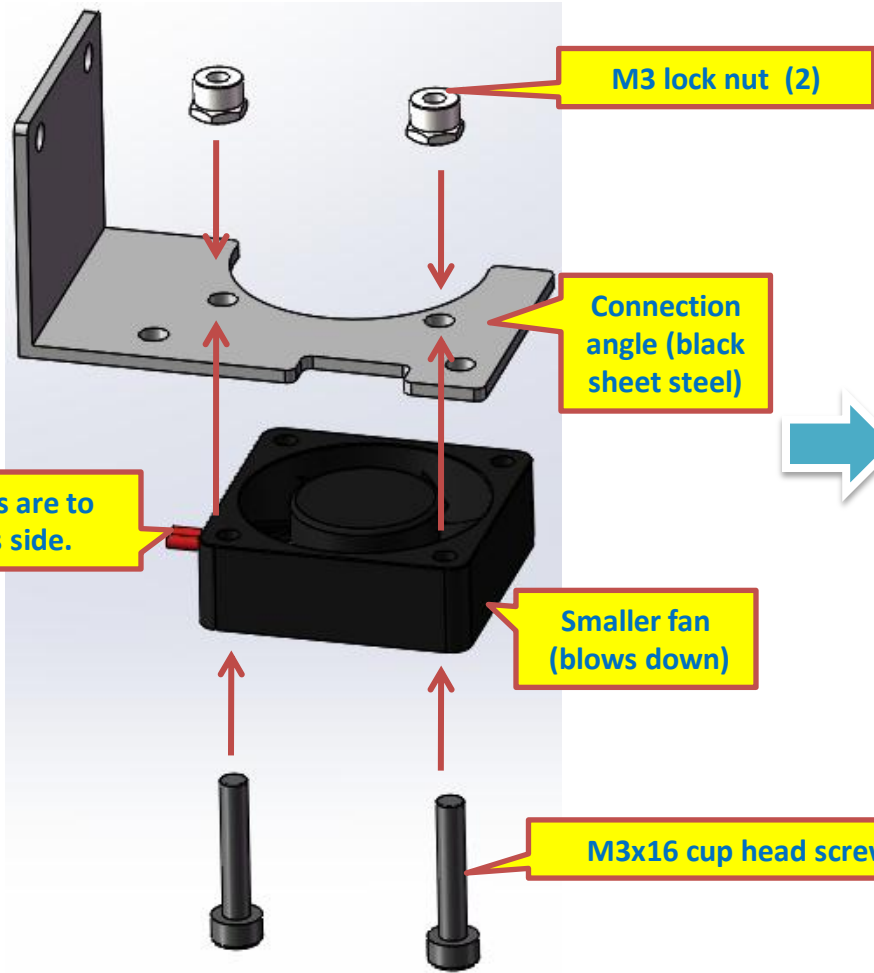
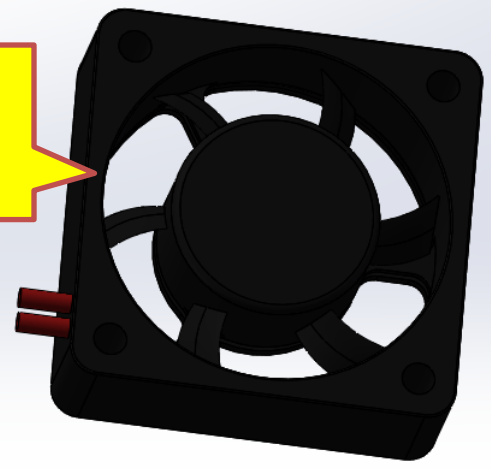
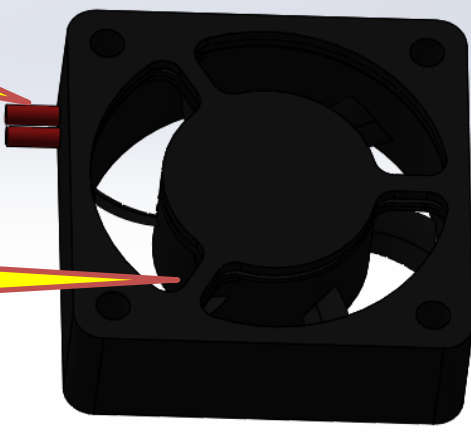

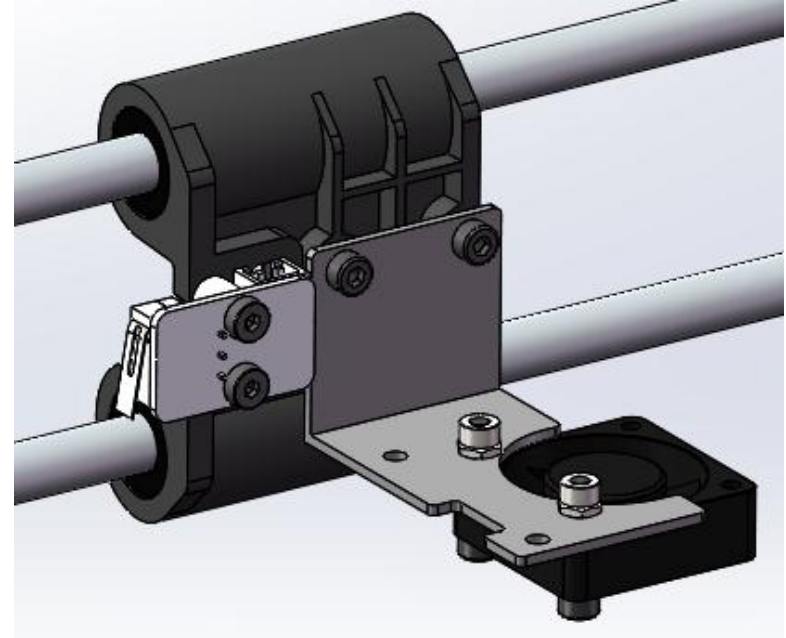
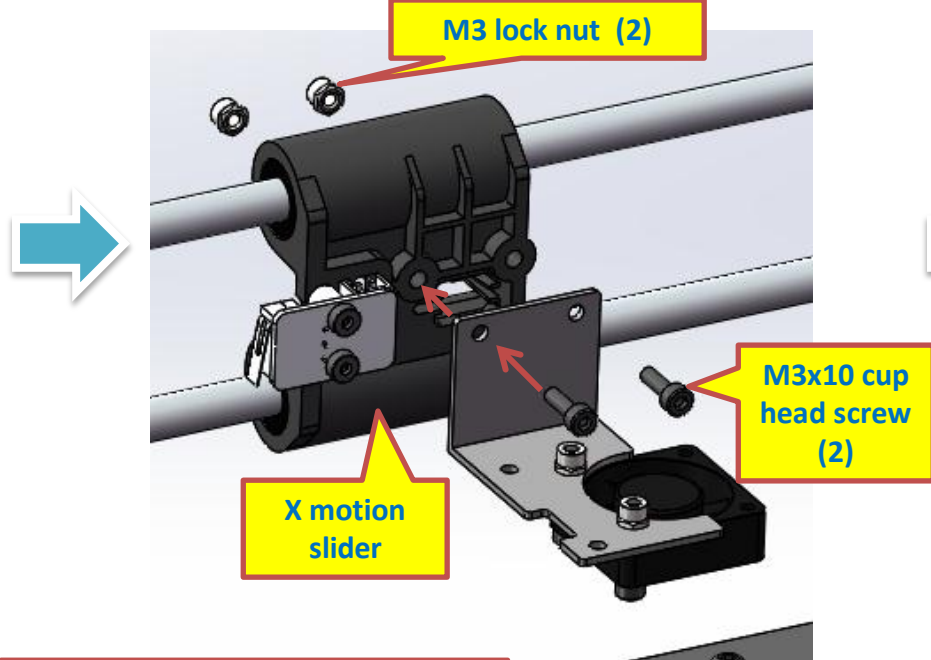

5.2 Install extrusion motor

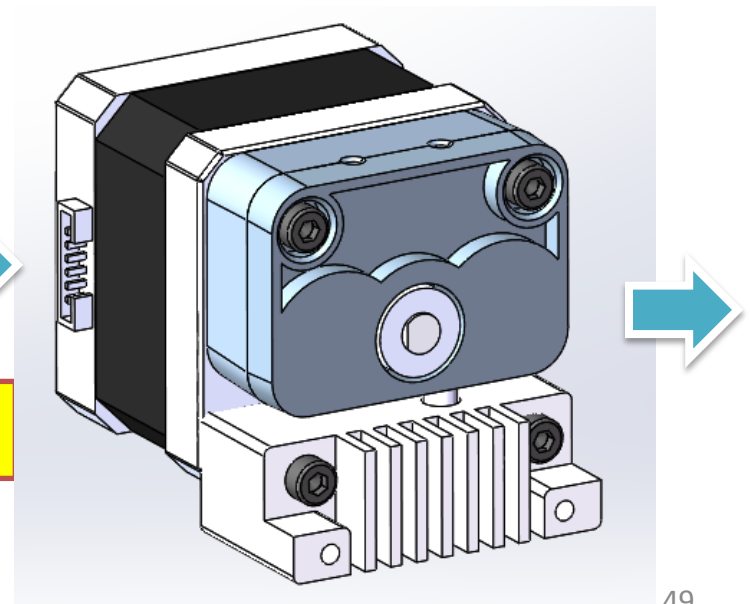
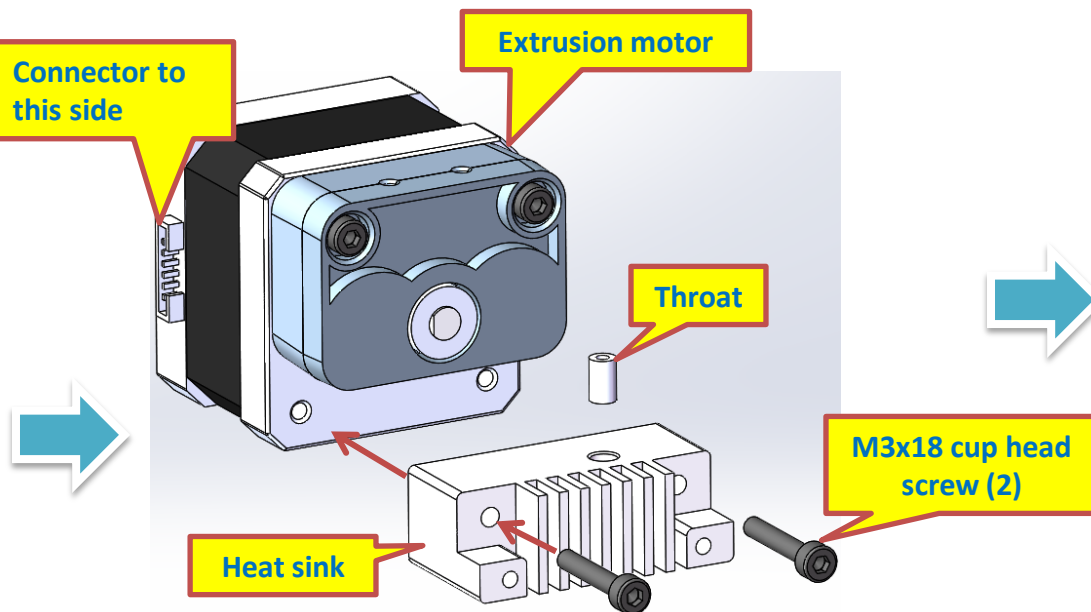

5.3 Assembly nozzle and connected components together

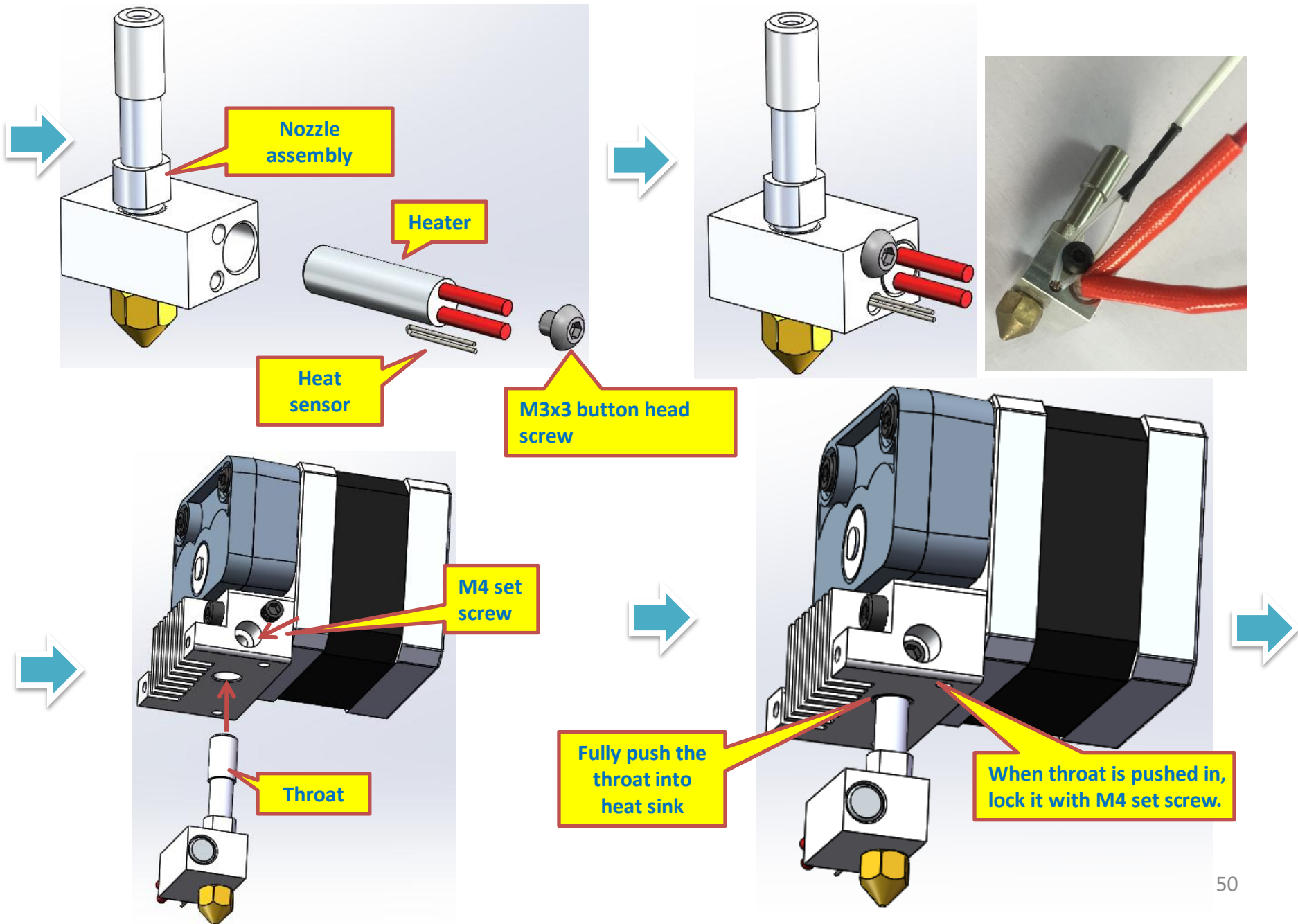

5.4 Install the bigger cooling fan

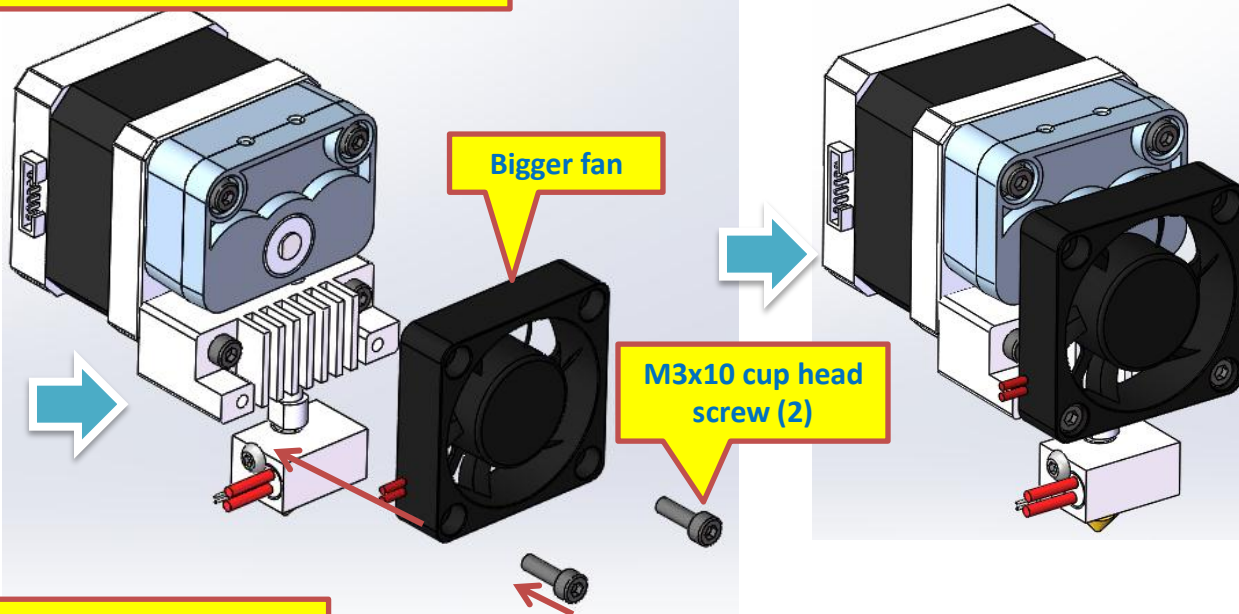

Wires of all parts are to the same direction as the picture shows.

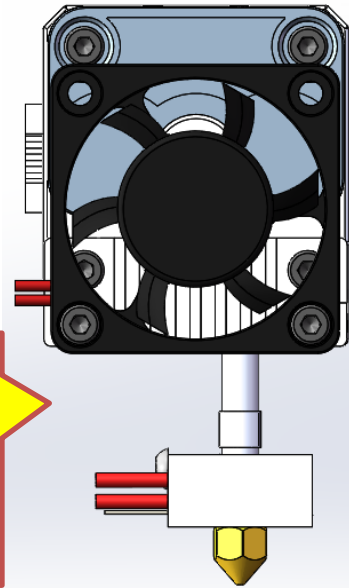

5.5 Nozzle assembly

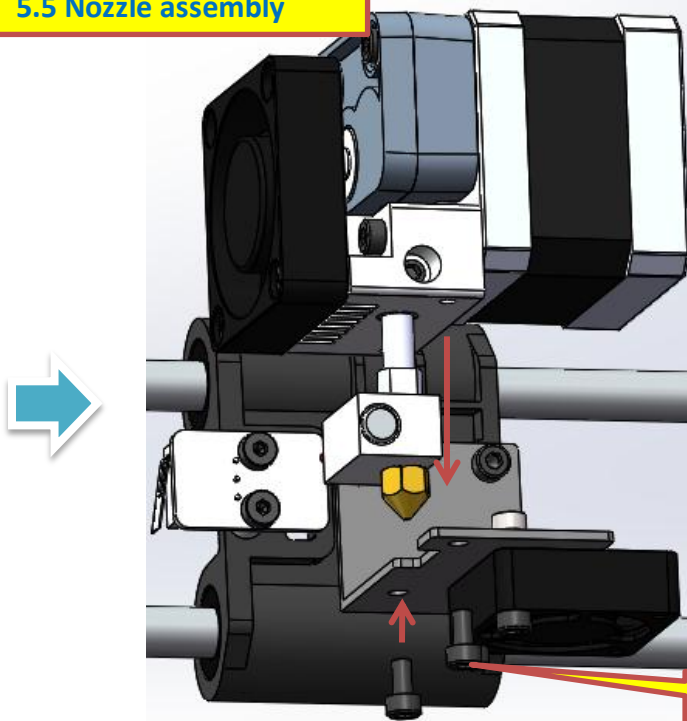

M3x6 cup head screw (2)

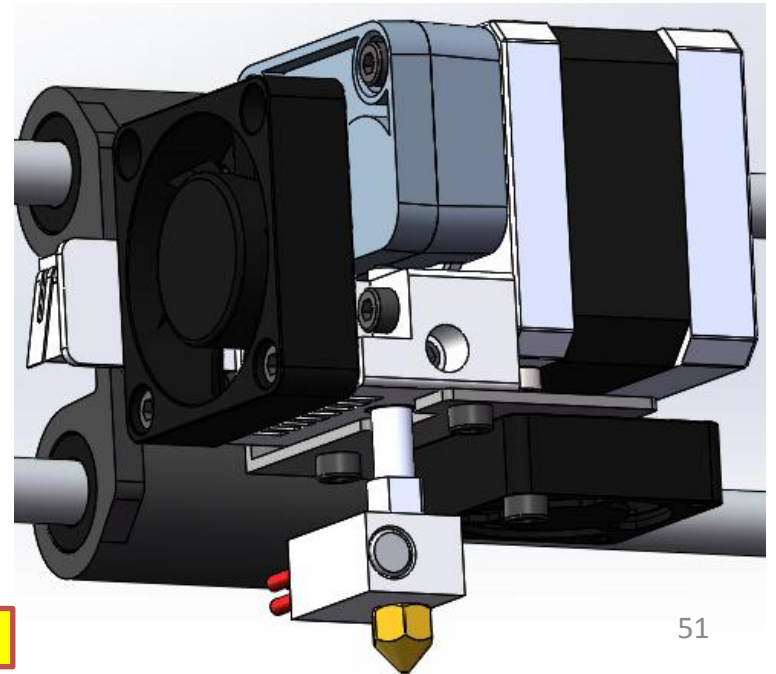

5.6 Install X motion belt

Timing belt

Teeth must be inside.

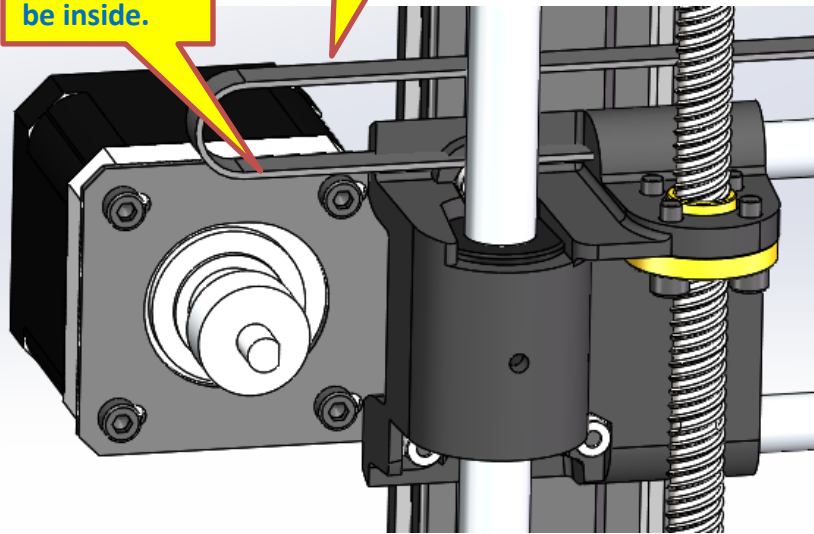

Belt around the Pulley

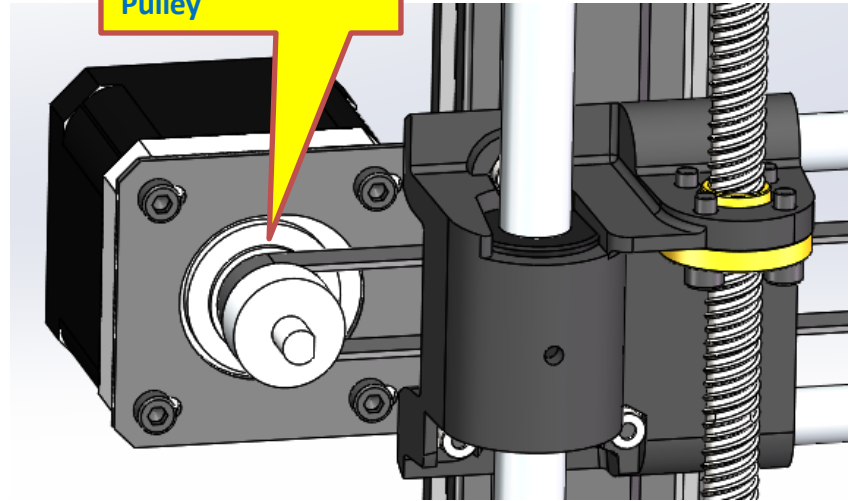

Belt around the idle pulley

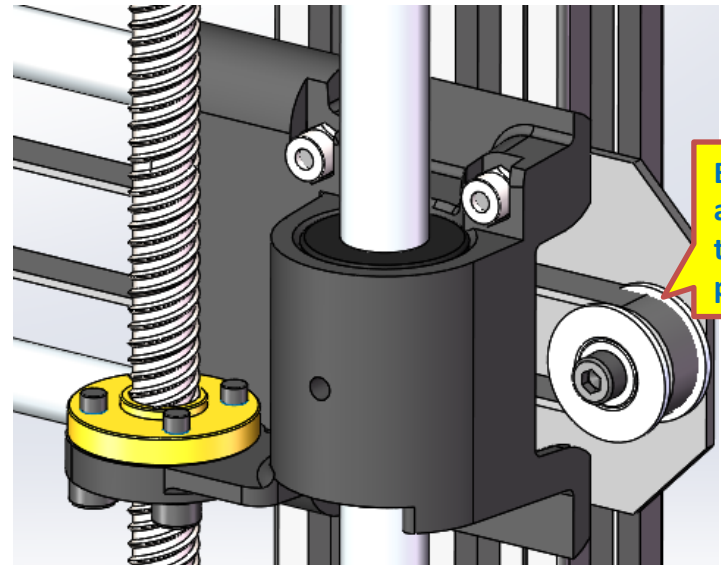

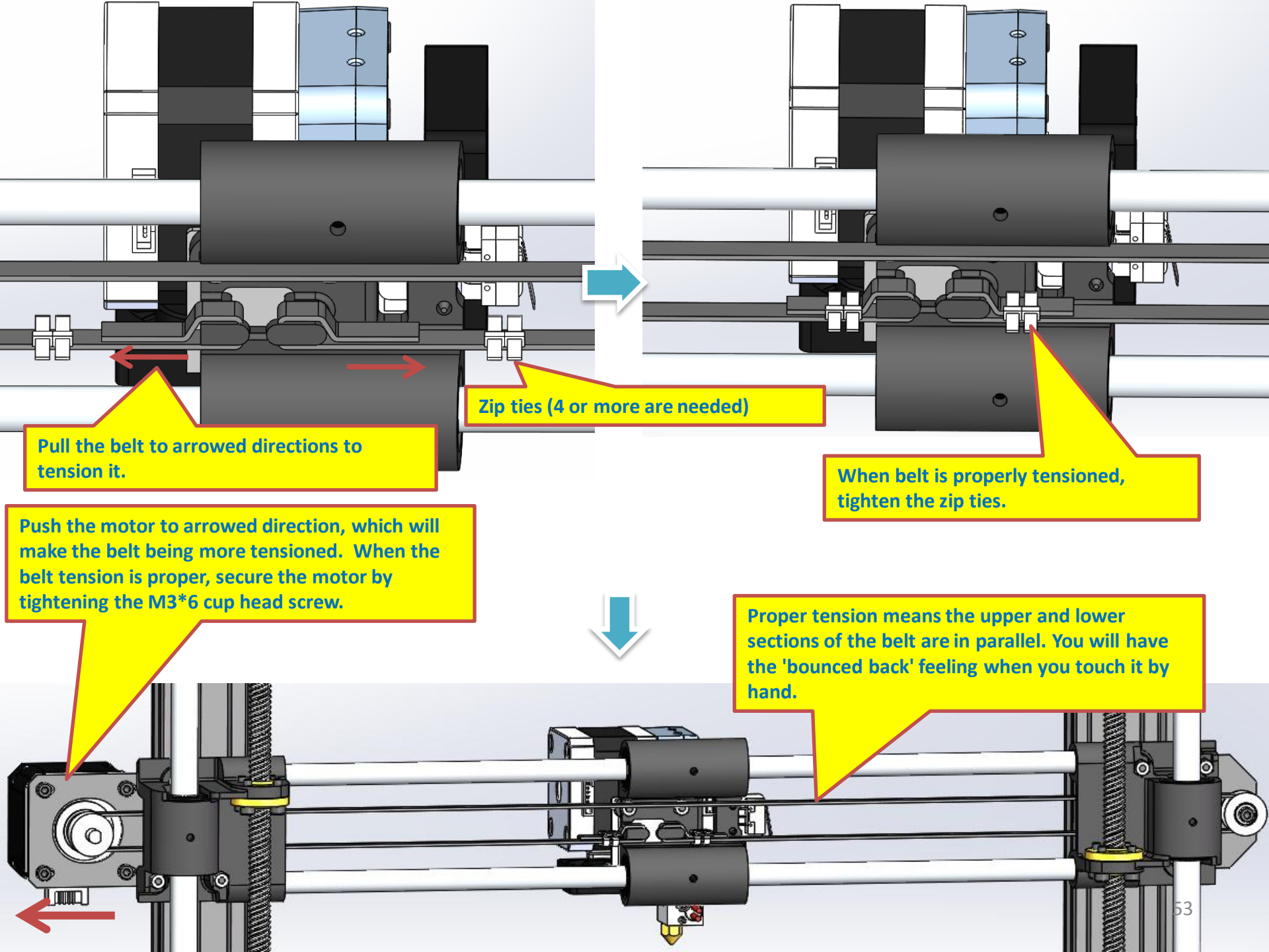

Pull the belt to arrowed directions to tension it.

Zip ties (4 or more are needed)

When belt is properly tensioned, tighten the zip ties.

Push the motor to arrowed direction, which will make the belt being more tensioned. When the belt tension is proper, secure the motor by tightening the M3*6 cup head screw.

Proper tension means the upper and lower sections of the belt are in parallel. You will have the 'bounced back' feeling when you touch it by hand.

Material list #5:

Sequence	#	Description	QTY	Remarks
Platform assembly	1	Heating plate	1	
Platform assembly	2	Top glass	1	Size: 220x200x3mm
Platform assembly	3	Clip	4	
Electrical circuit	4	Control box	1	
Wire	5	Power cord	1	
Binding tube	6	Binding tube	2	
Power supply	7	Power adaptor	1	



6.1 Install heating plate on platform

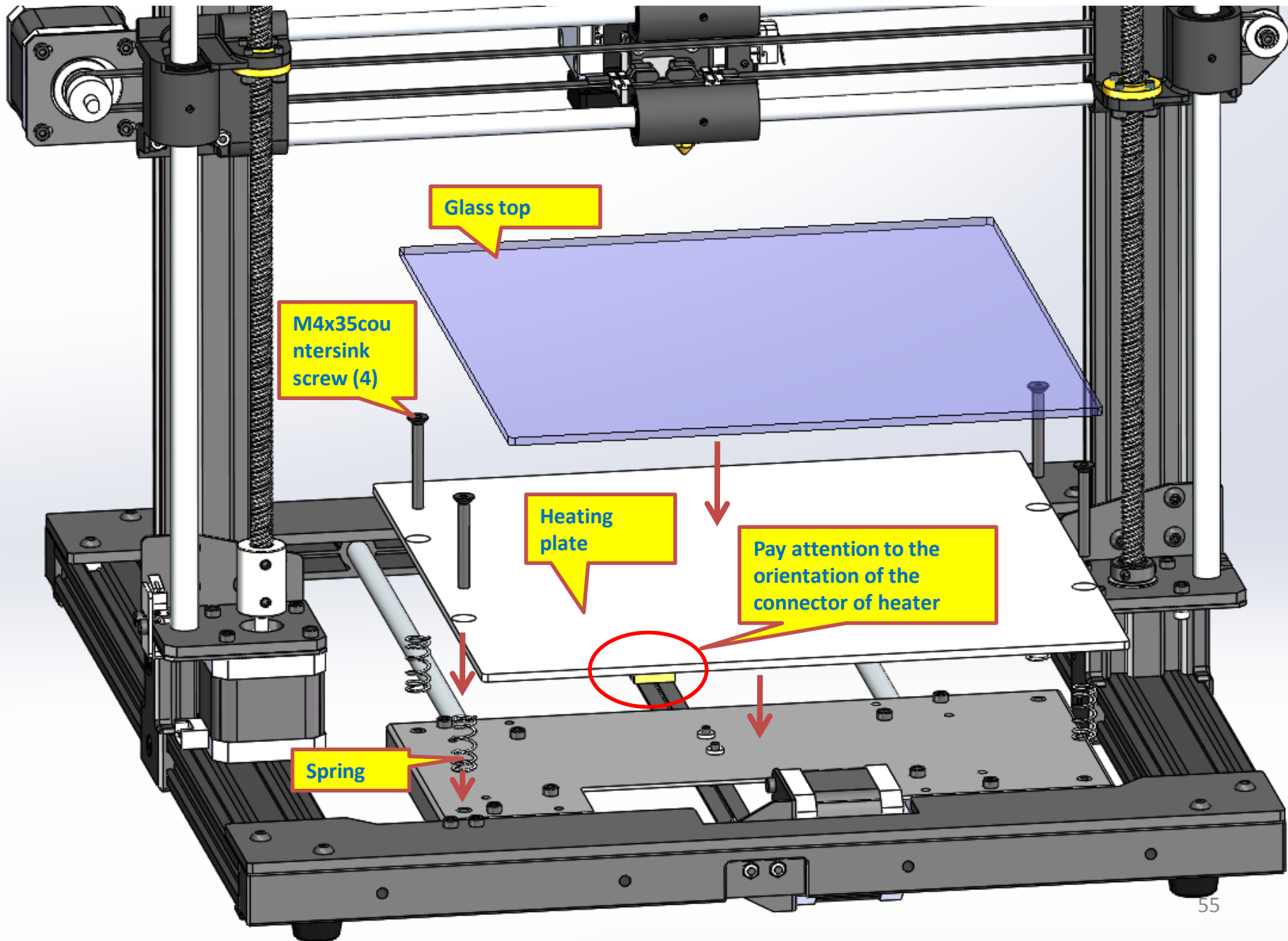

6.2 Install the top glass of platform

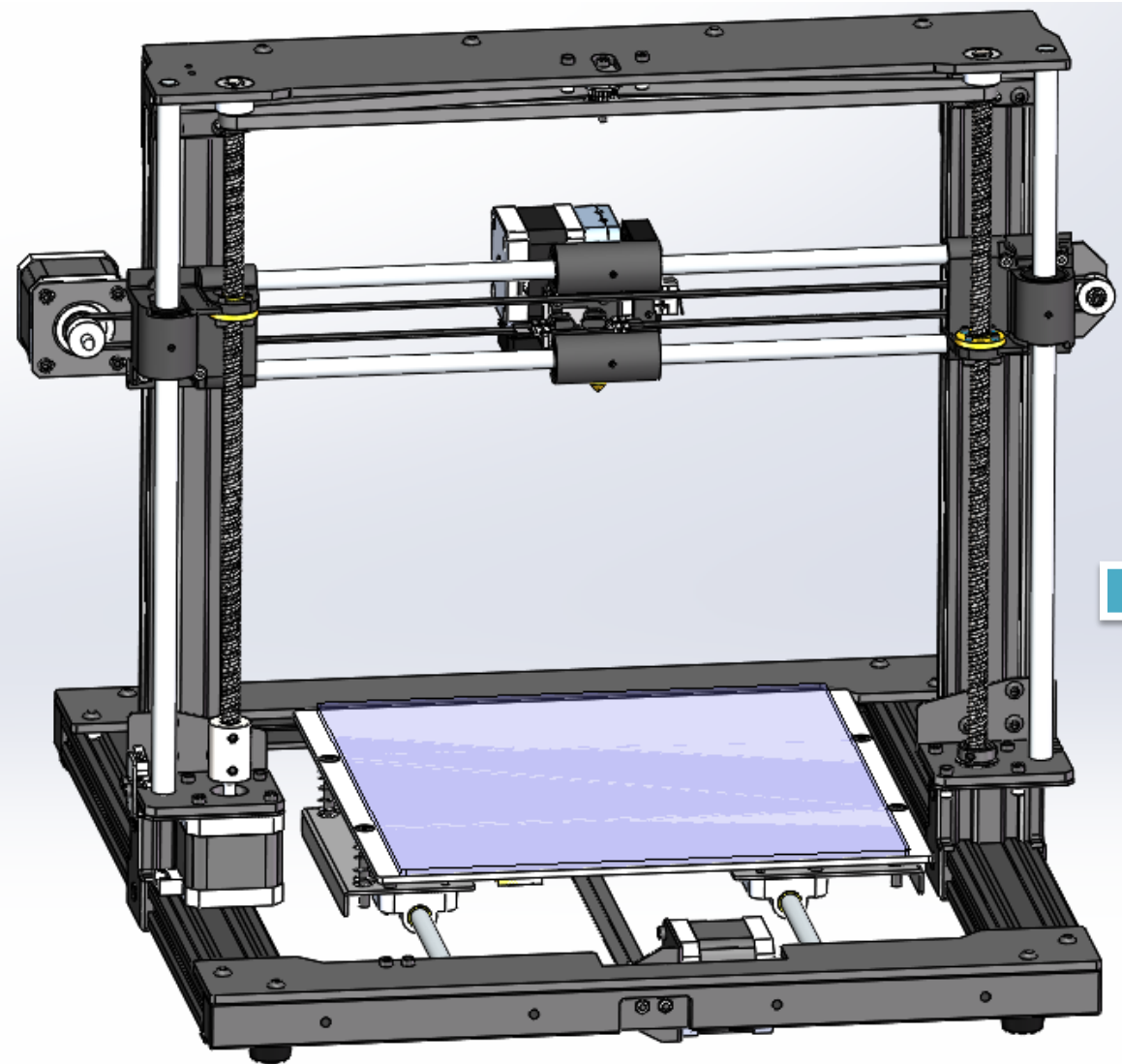

Use clips to fix the glass on the heating plate

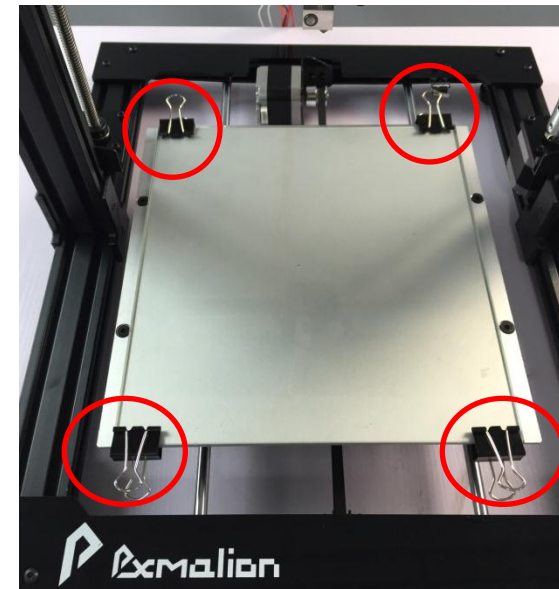

Material list #6:

#	Descriptions	# of wires	Connector color	Position
1	Bigger fan	2P	Yellow	A
2	Smaller fan	2P	Red	B
3	X- Stroke switch	2P	Black	C
4	Y- Stroke switch	2P	Blue	D
5	Z- Stroke switch	2P	White	E
6	Heater	2P	Green	F
7	Heat sensor	2P	Green	G
8	Heating plate	4P	Red	H
9	Extrusion motor	4P	Yellow	I
10	X motion motor	4P	Black	J
11	Y motion motor	4P	Blue	K
12	Z motion motor	4P	White	L

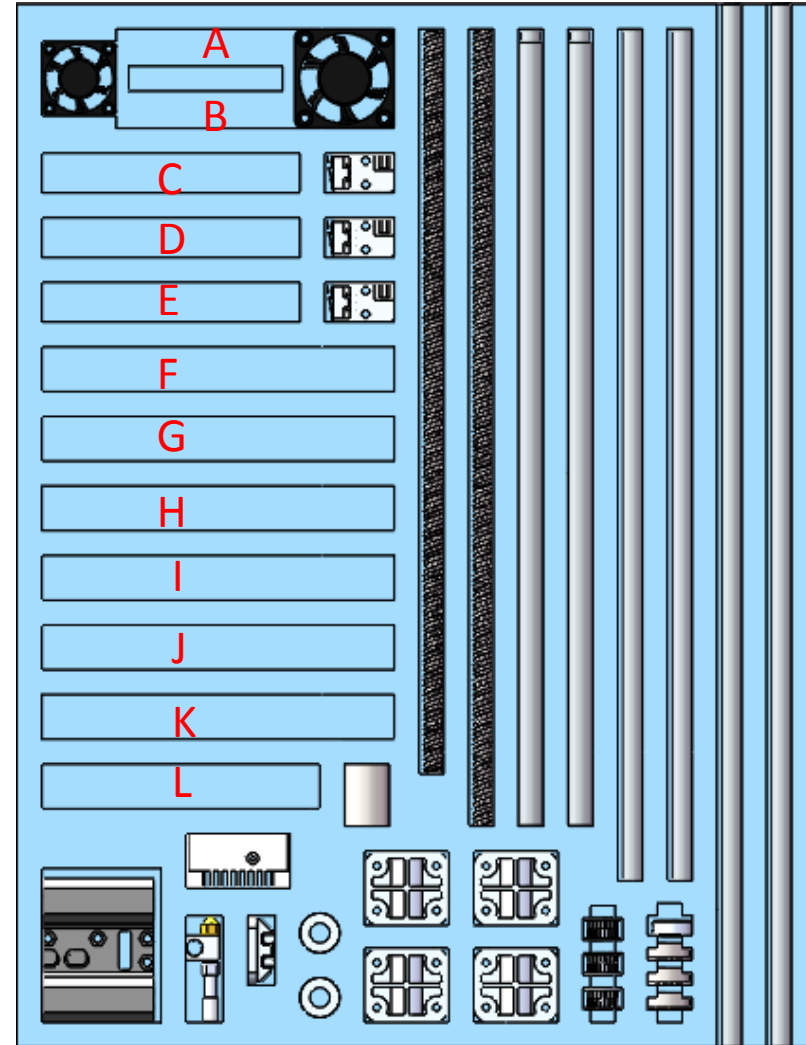

Where to fine the wires in the foam tray

7.1 Where to connect the wires --- 3d printer side

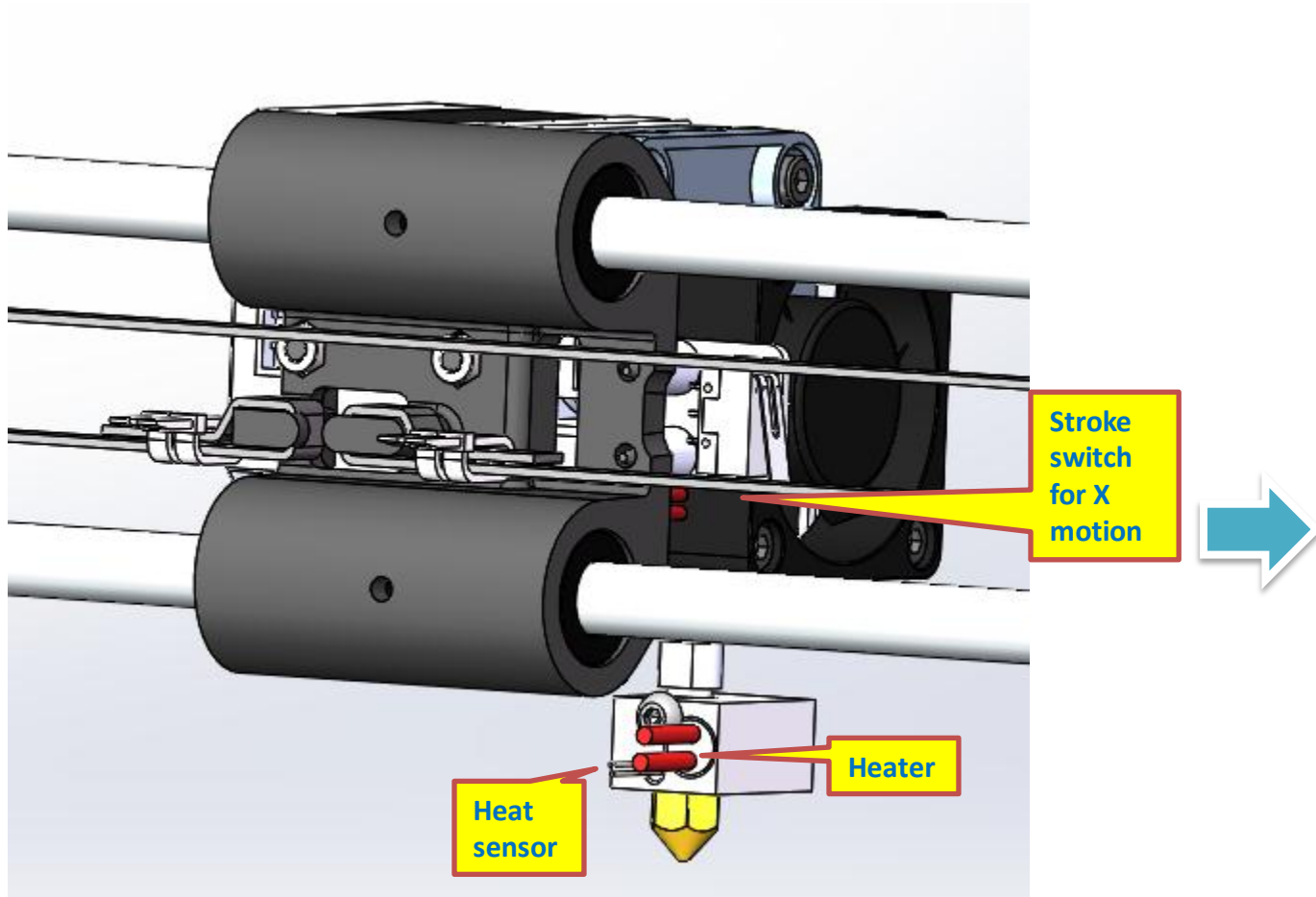

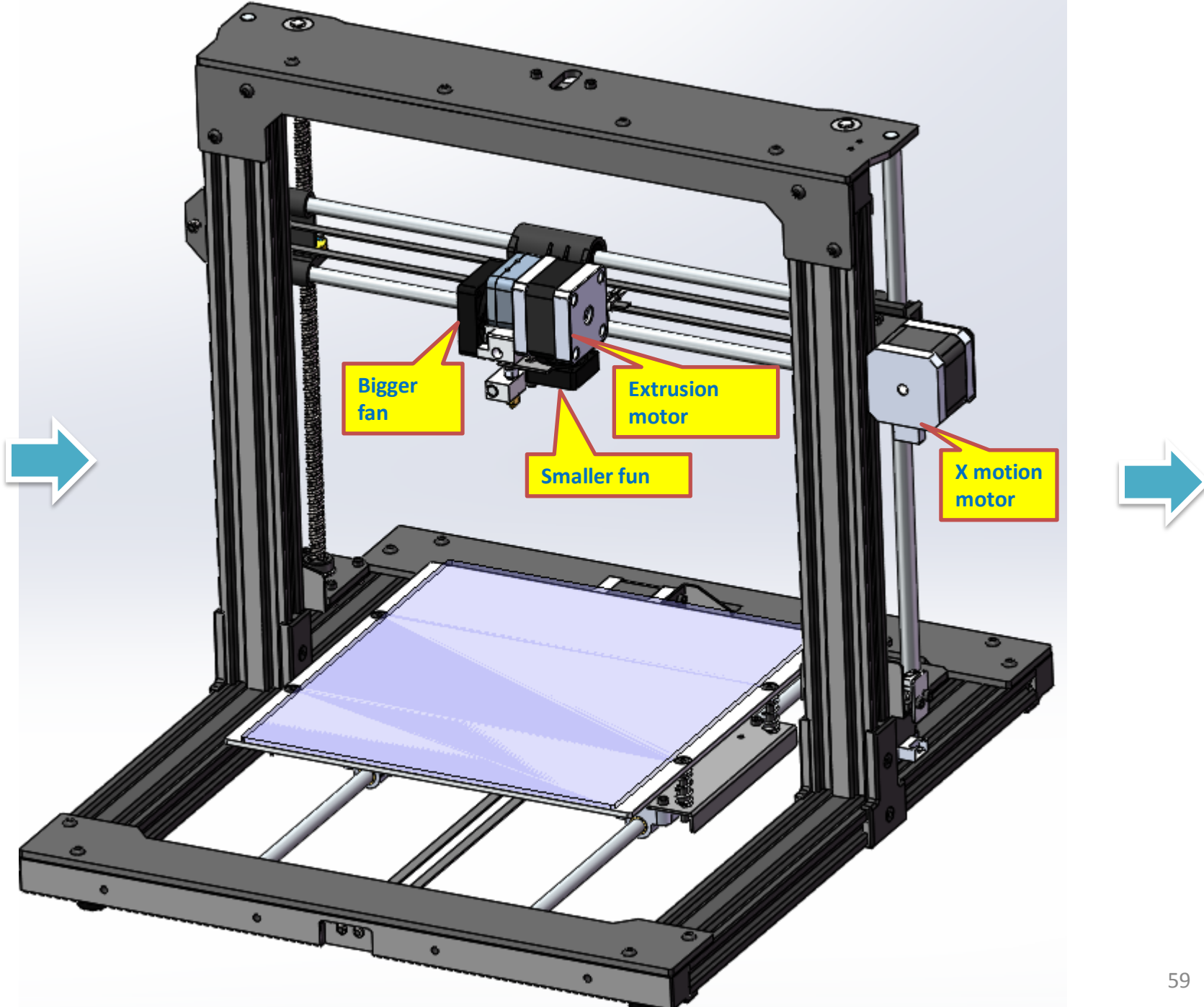

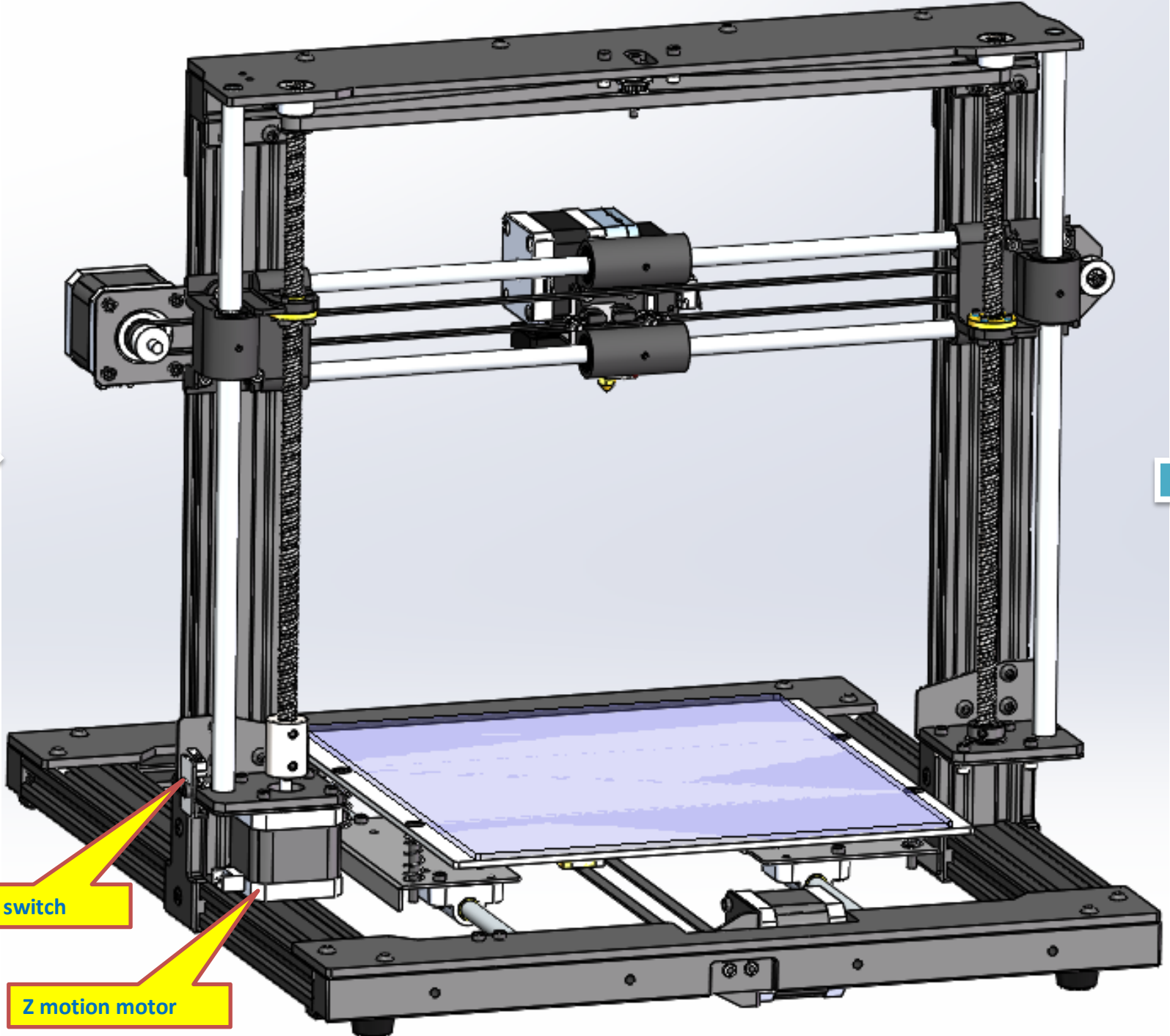

Z-Stroke switch

Z motion motor

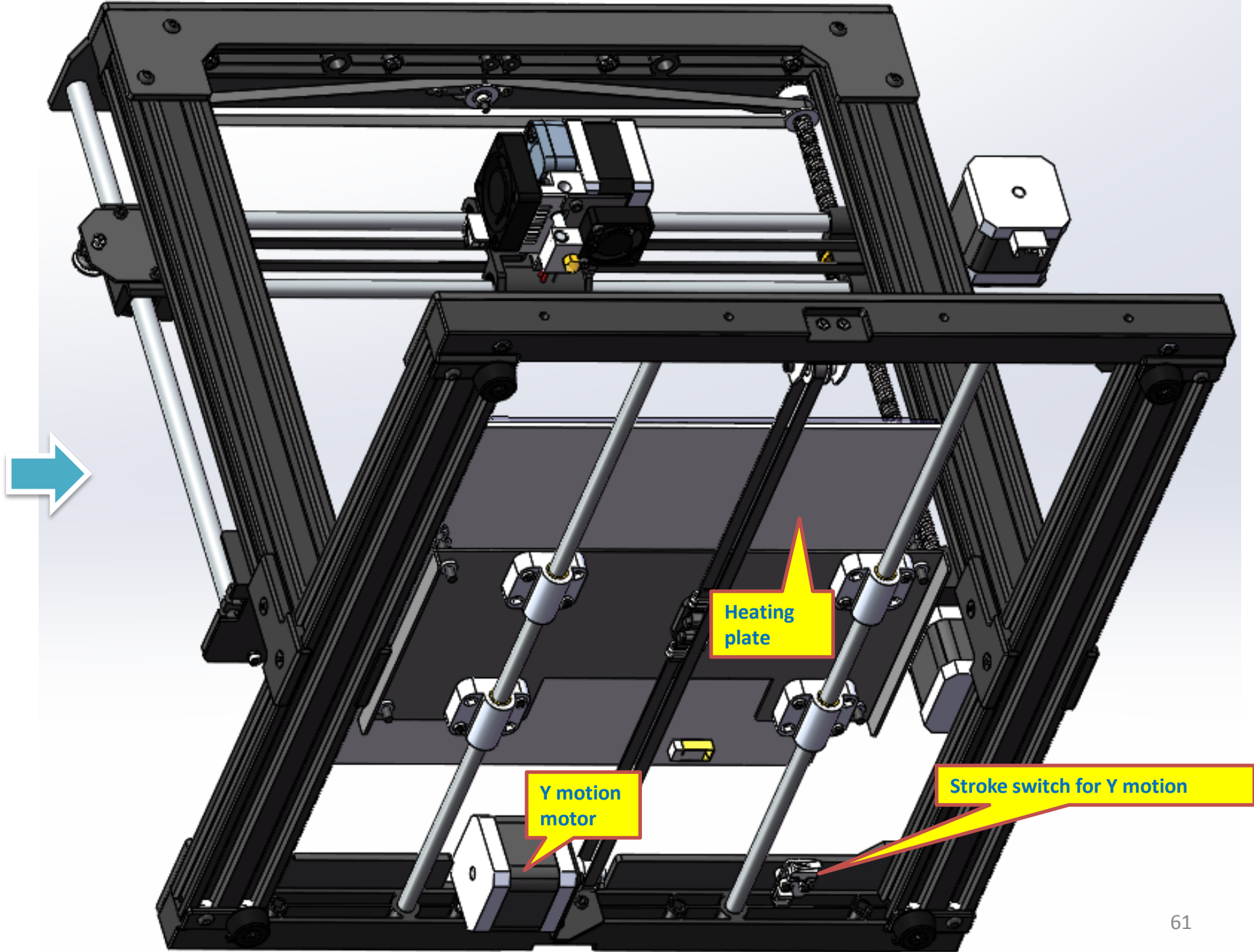

Heating plate

Y motion motor

Stroke switch for Y motion

7.2 How to connect wires to the control box

As shown at right side, the yellow circled connectors will be plugged into related hardware (such as motors, fans, heater, etc.)

The connector at the other end will be connected to the motherboard, where has matching connectors in the same colors.

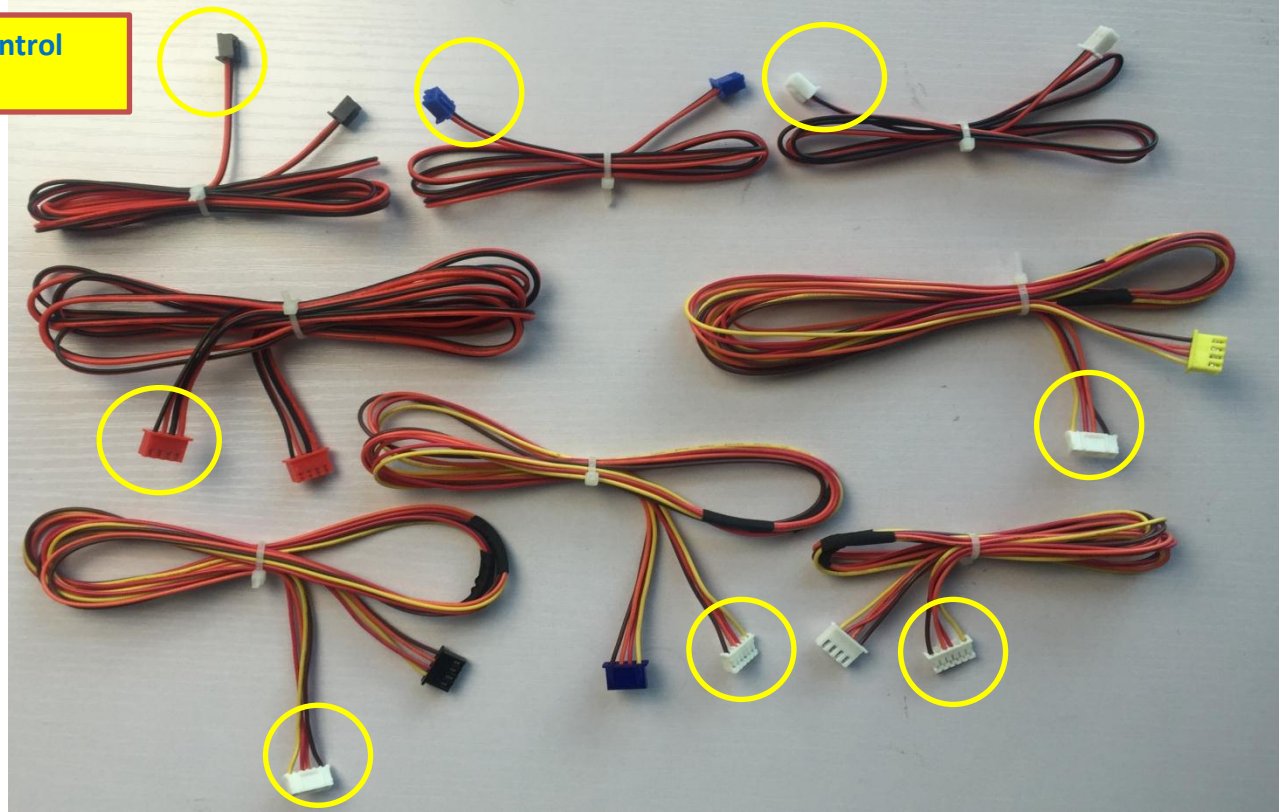

- ① Remove these 4 screws to open the box.
- ② Mate connectors according to their colors.
- ③ Assemble the box back.

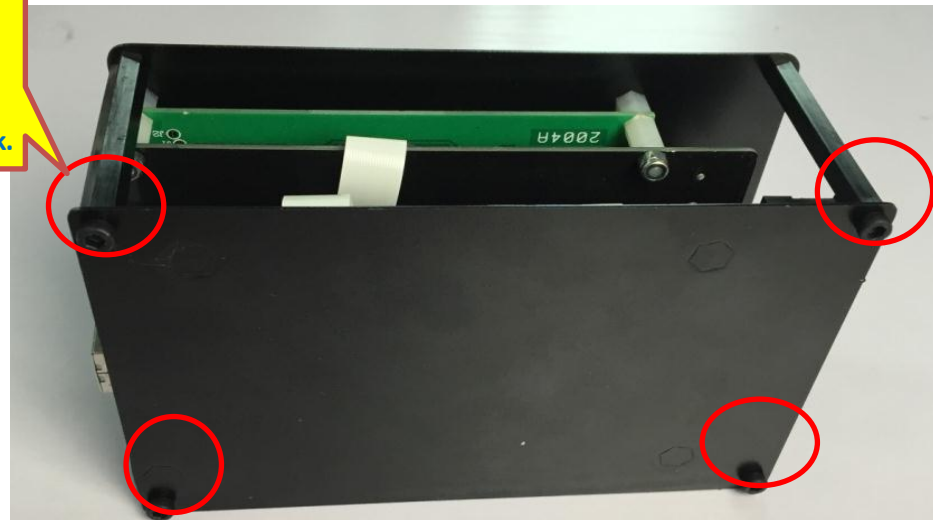

Mother board connector map

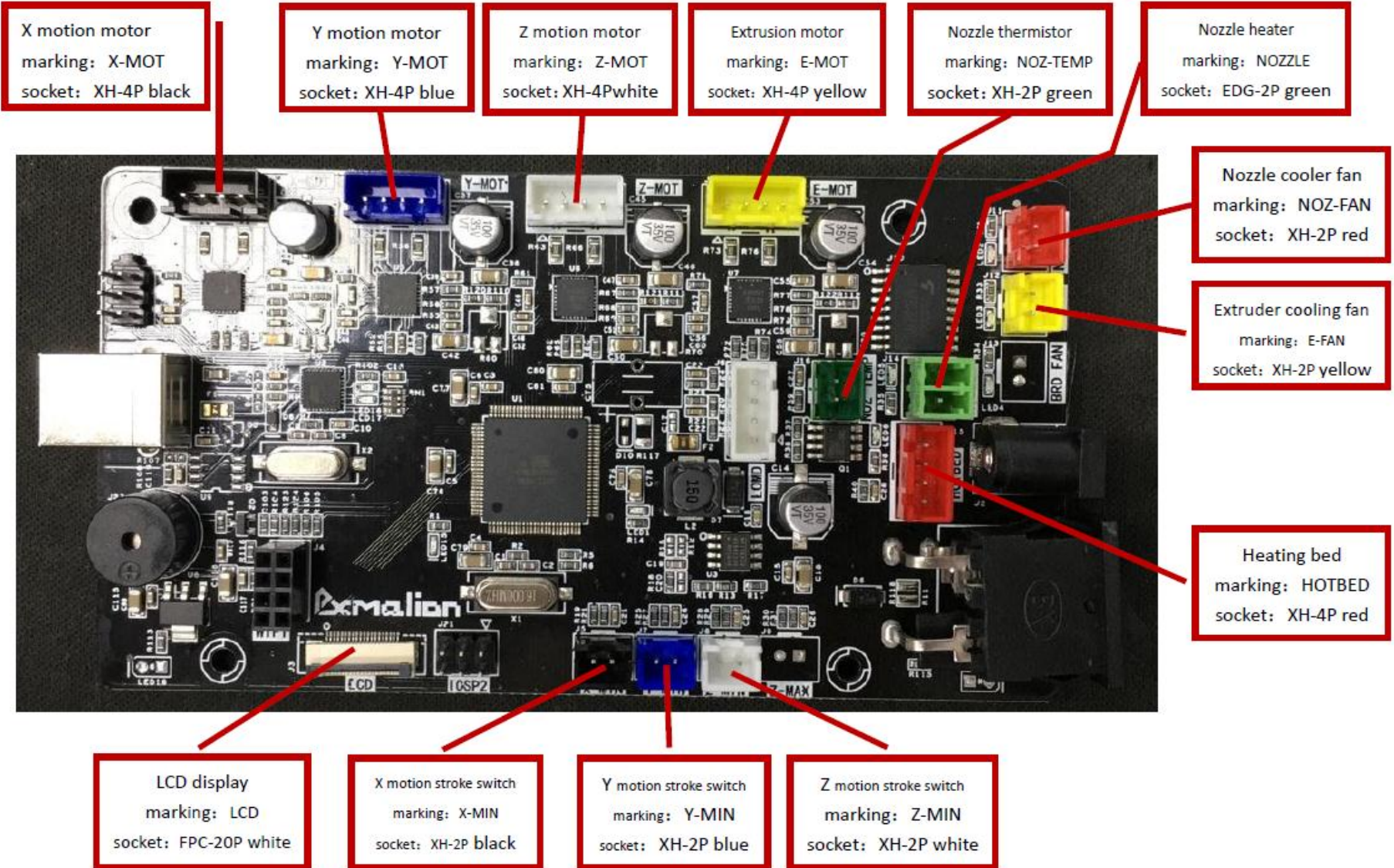

8.1 Adjust smoothness of Z axis motion

Power on the unit



Operation: Enter Info screen, click then turn the knob, click Prepare then Adjust Z axis. Nozzle assembly will start to move up and down, and repeat for 3 full cycles.

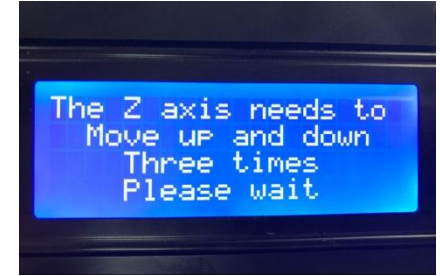
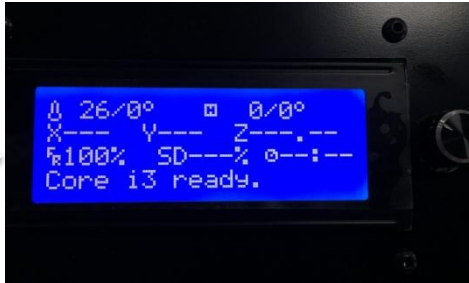

8.2 Please loosen those screws in red circle before making nozzle moving up and down. While the nozzle assembly is moving, tighten those screws little by little. The parallelism of the 2 screw rod and guiding pins for Z motion can be adjusted effectively by repeating the action. You can hence repeat it for a desired result.



- ① Please loosen these 6 screws first.
- ② While nozzle assembly is moving up and down, tighten them gradually.

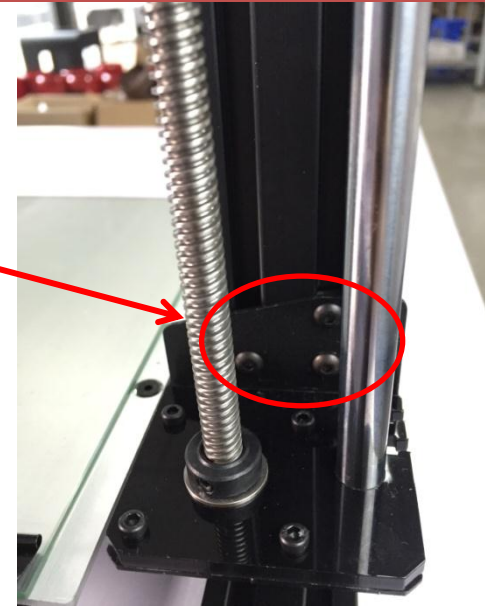

Finished

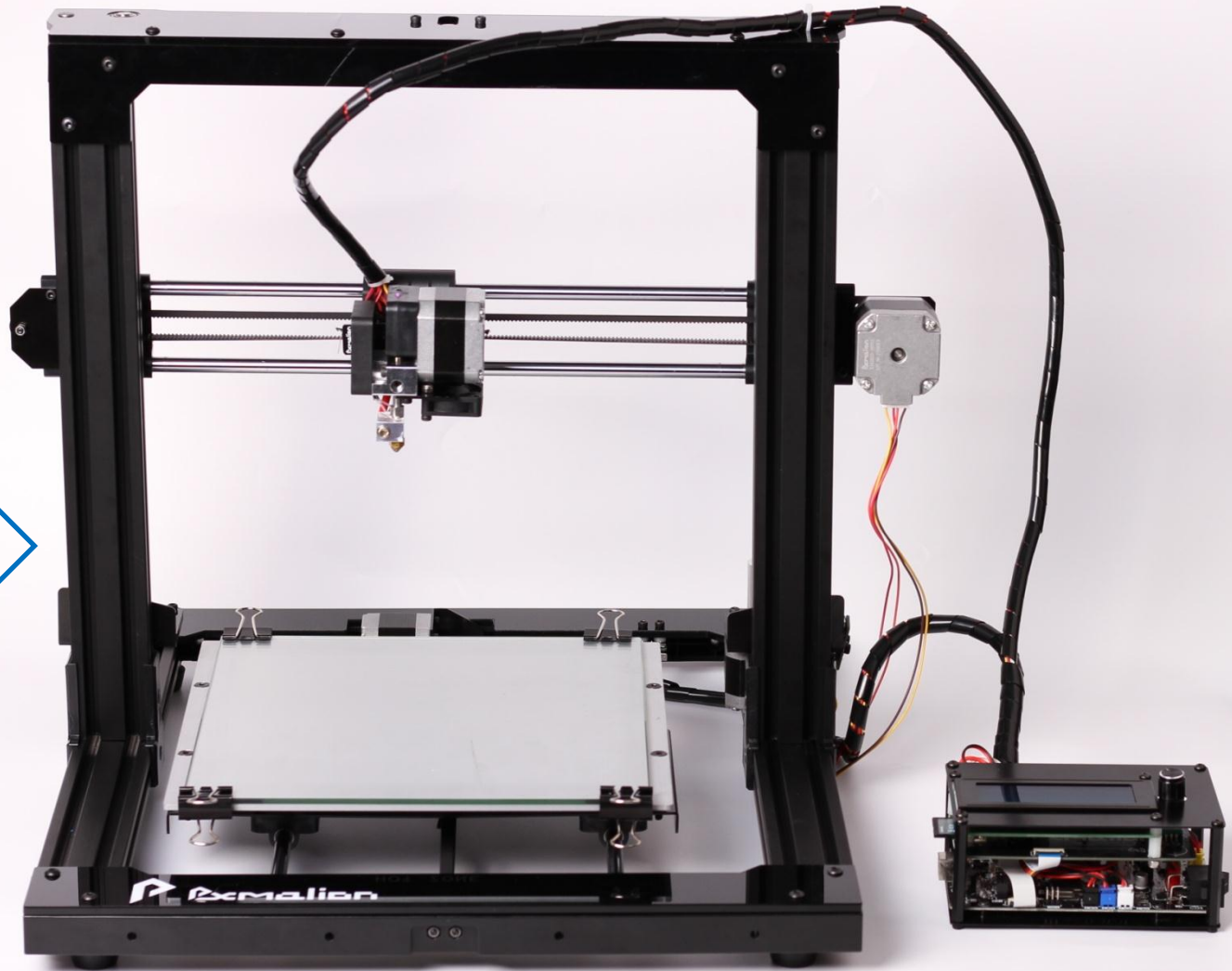

9. Filament sensor installation

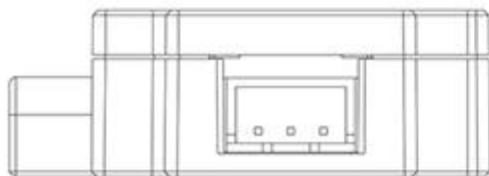
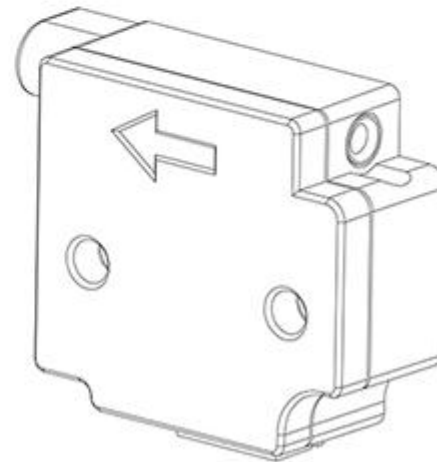
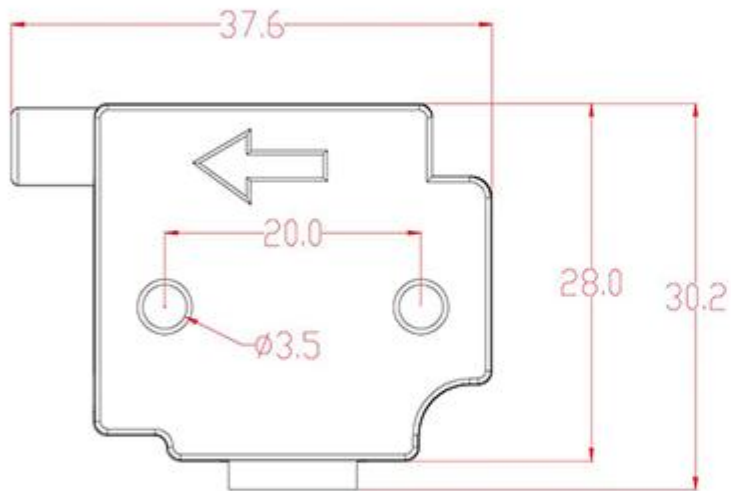

9. Filament sensor installation

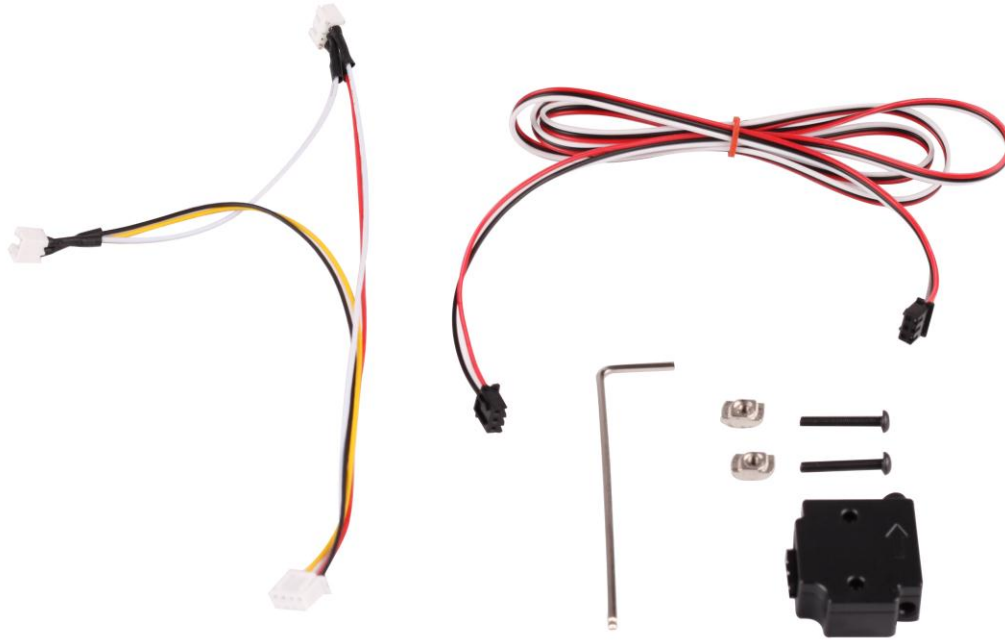

Tools used for installation:

1 x Filament sensor

2 x Cup head hex socket screw M3x20mm

2 x T nut M3

2 x Cables

1 x 2.5mm Allen Keys

9. Filament sensor installation

2 M3x20 screws pass through filament sensor. Then 2 T nut M3 cover the 2 M3x20 screws separately and screw the T nut M3 by 3 turns (over fastening may be difficult to install later).



9. Filament sensor installation

The cable has a 3-pins port and a 2-pins port. The 3-pins port is used to connected with the filament sensor. The other 2-pins port is to connect the auto leveling.

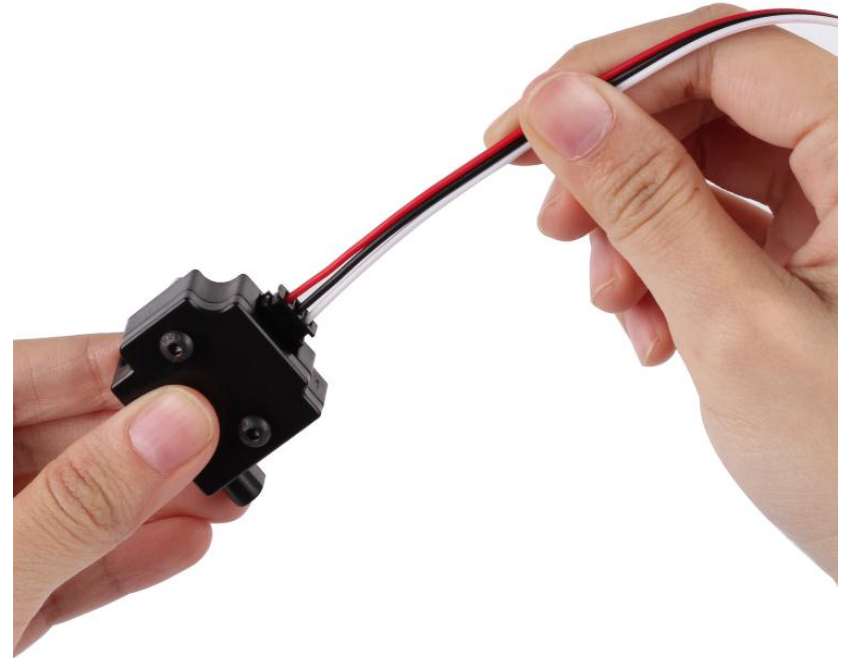
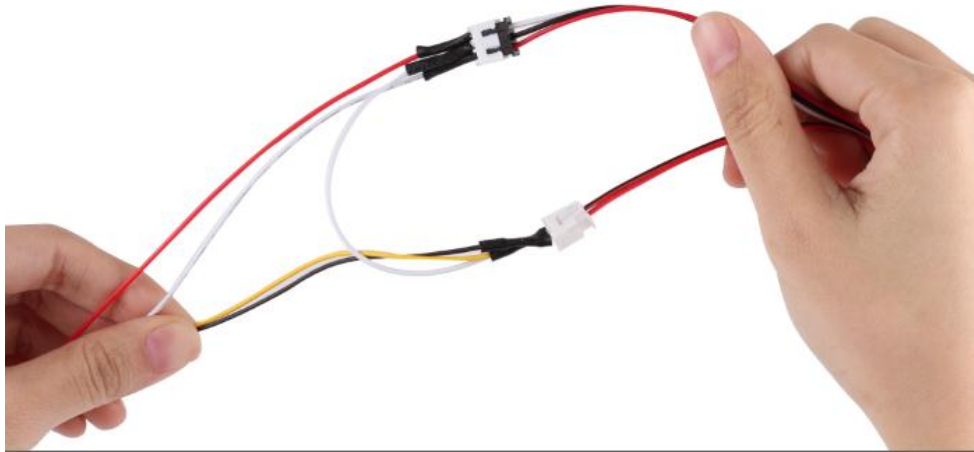

9. Filament sensor installation

Connect sensor with the 4-pins port to the 3d printer via the white port shown in the below image.

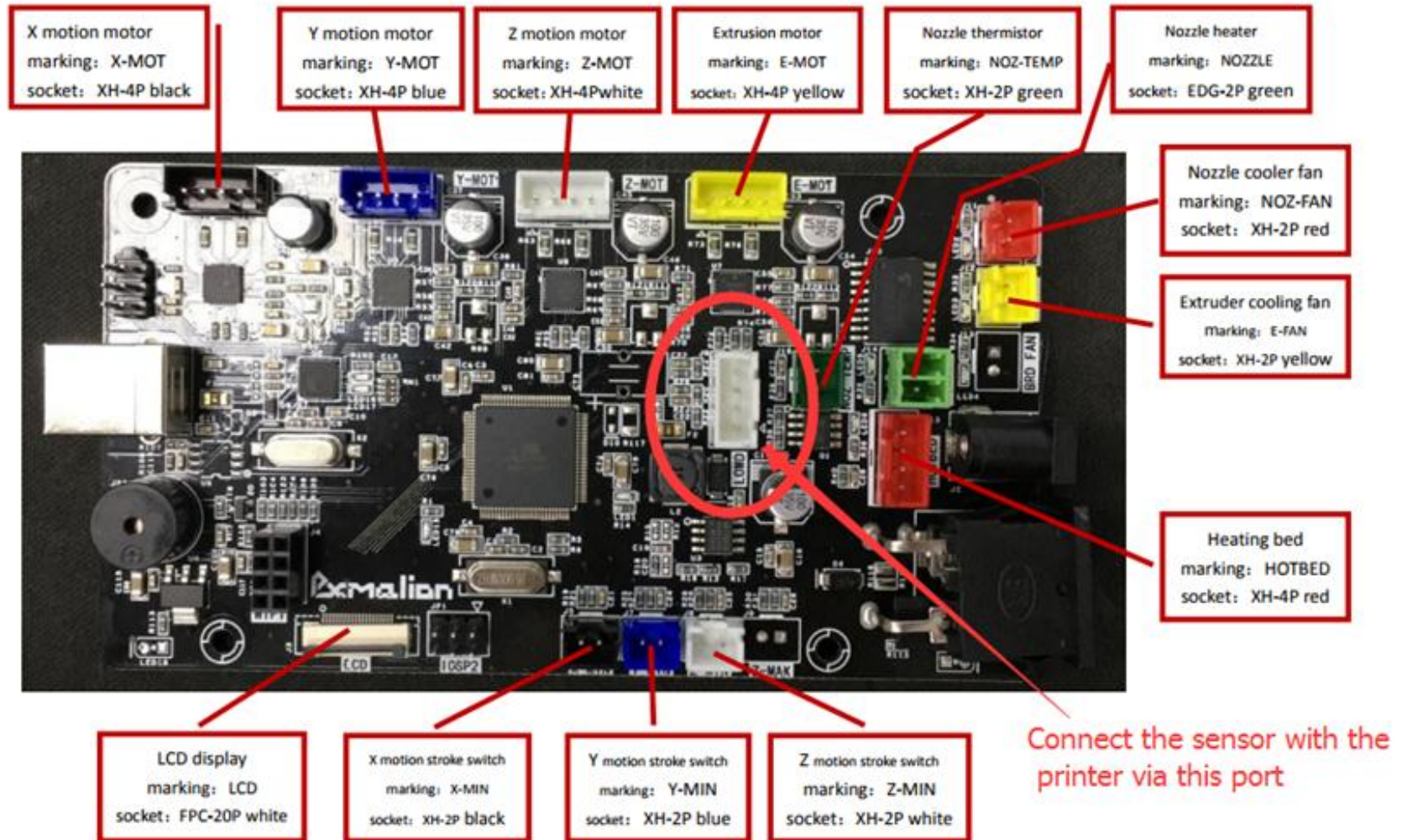

9. Filament sensor installation

You are advised to install the sensor on the place shown in the below image.

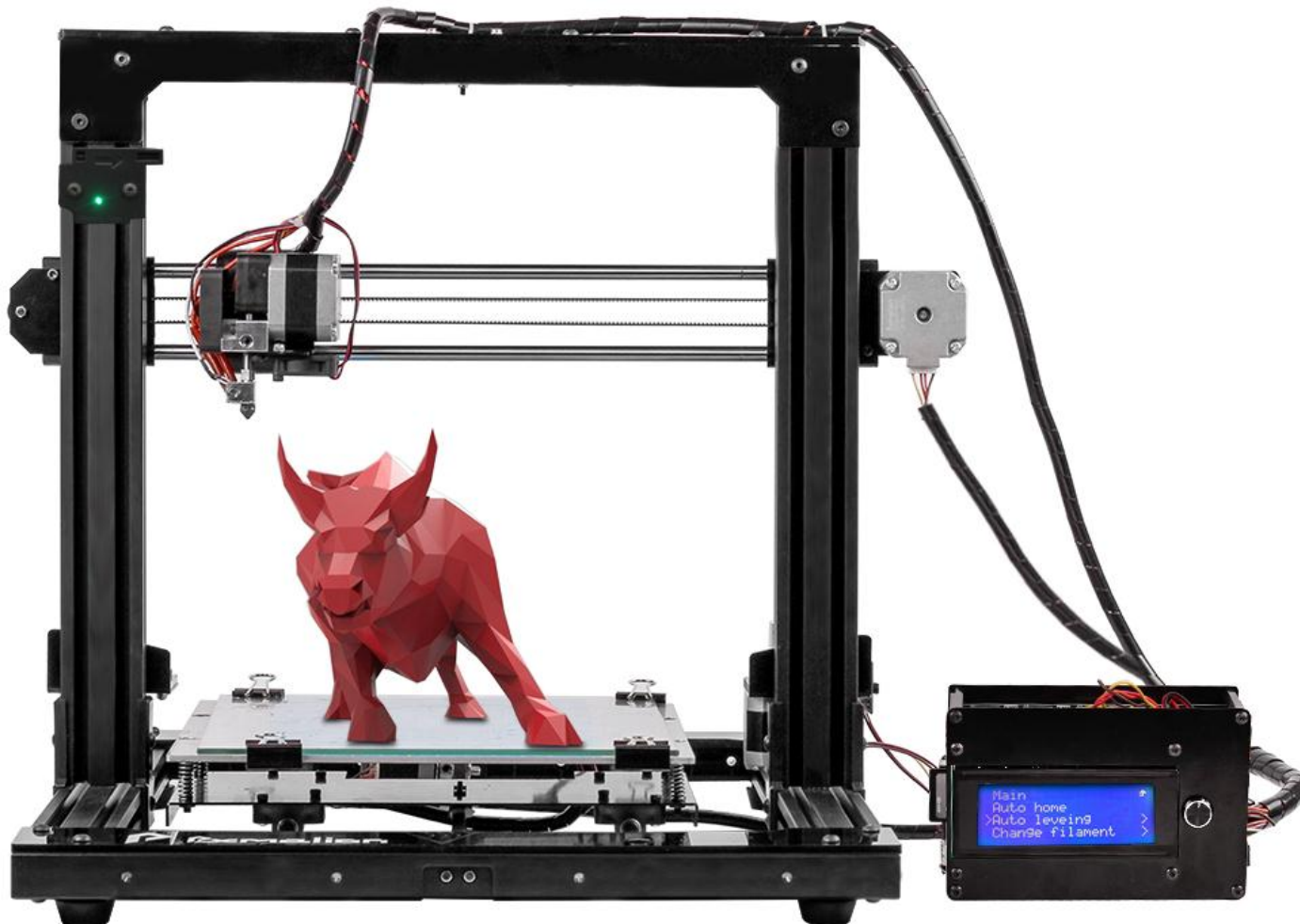

9. Filament sensor installation

Turn the T nut M3 and insert them into the groove inside.

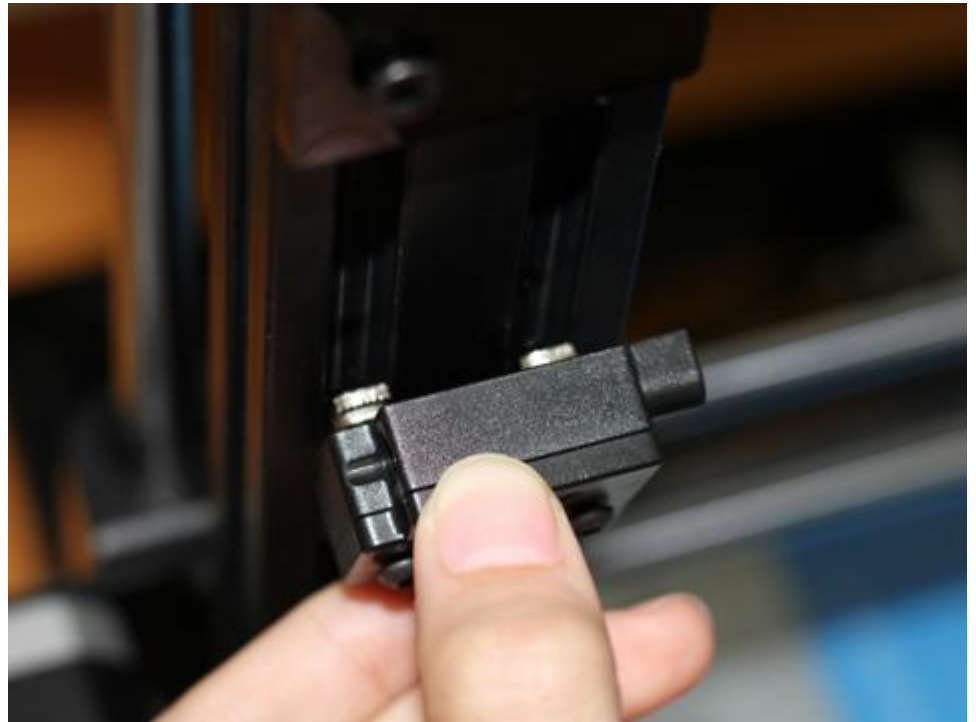

9. Filament sensor installation

Use 2.5mm Allen key to fasten both of them.



9. Filament sensor installation

Insert the filament through the hole into the extruder.

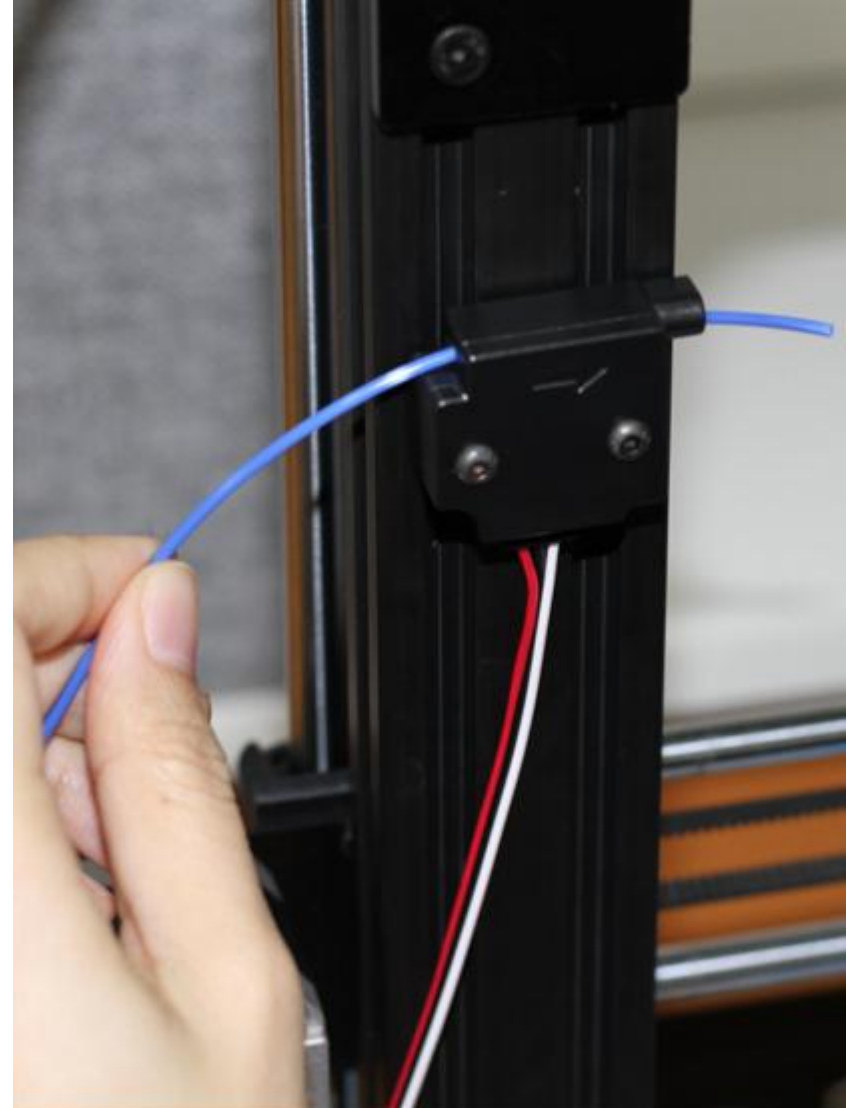

9. Filament sensor installation

Check for the sensor after installation

1. Enter 'About Printer' => 'Sensor Info'. If:

- If the data of 'FIL' shows '1', it means the sensor detects filament and the installation succeeds.
- If the data of 'FIL' shows '0', it means the sensor cannot detect any filament. You are advised to recheck the wiring. If you can't verify this issue, please contact Pxmation for further support.

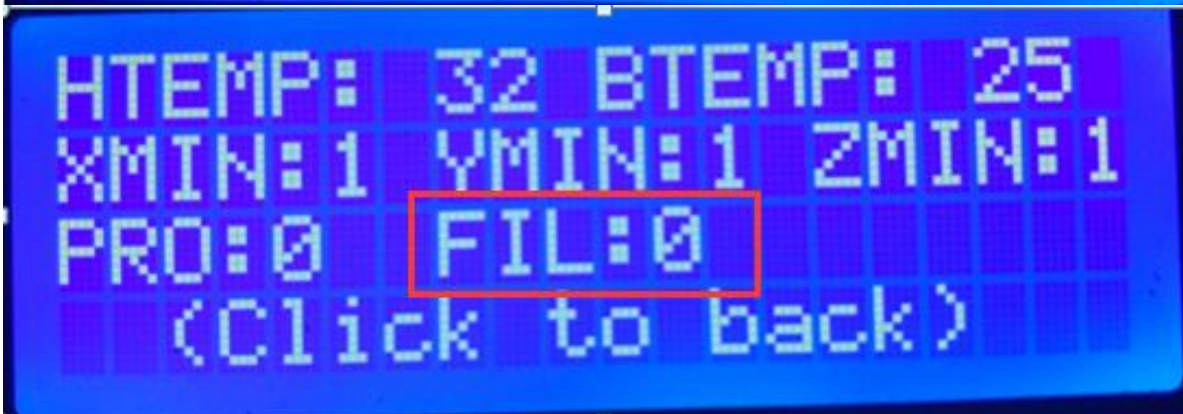
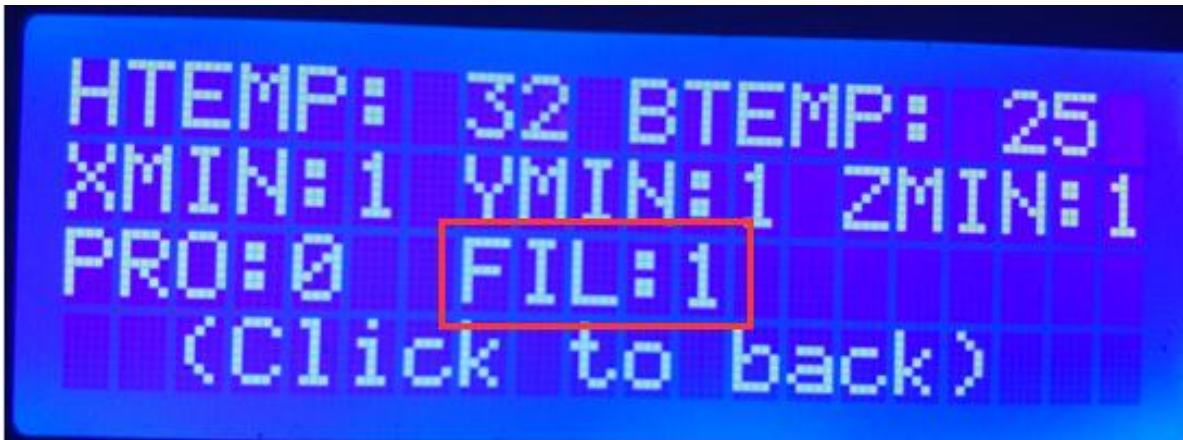

10. First print after set up

Offline printing

1. Enter 'Prepare' -> Change filament -> Load filament. After loading filament, you can start test printing. There is a Gcode files in SD card. Enter menu -> Print from SD -> click square.gcode.

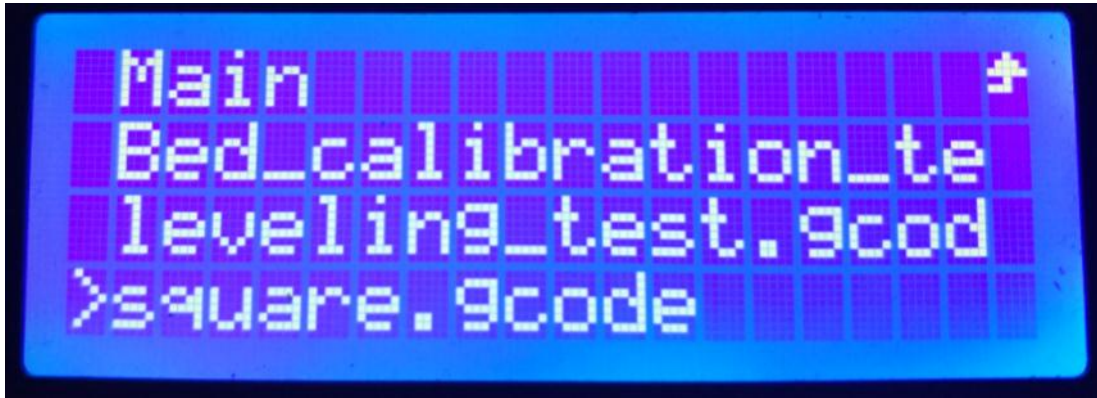

2. Printer will start printing a small cube.

Heat bed temperature of 'square.gcode' is 40 centigrade. Extruder temperature is 203 centigrade. The setting works for most PLA filaments. For all kinds of PLA, It's suggested to do adjustment in Cura in order to have better results.

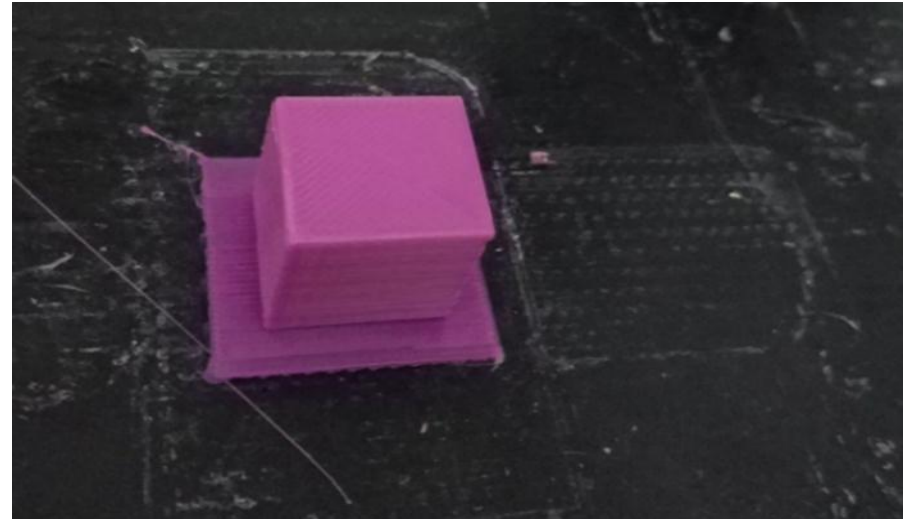

10. First print after set up

Offline 3D printing with SD card

Users can use Cura, Simplify 3D or Repetier to do slicing and output Gcode file. Users should consider the size of extruder, printing size of Pxmation 3d printer and the type of PLA filament to be used.

Save Gcode file in SD card. Insert SD card into SD slot and follow the steps the same as print from 'square.gcode'.

Note:

1. Pxmation CoreI3 Kit provides slicing software of 14-16 version. If the Cura included in SD card isn't compatible with your computer, please download the corresponding version.
2. If you prefer Simplify 3D or other slicing software, you can do slicing by referring to the setting in Cura.